



Please read this document carefully before using this product. The guarantee will be invalidated if the device is damaged by not following instructions detailed in the manual. The company shall not be responsible for any damage or losses however caused, which may be experienced as a result of the installation or use of this product.

# ENDA EPAC3-W-F SERIES PHASE ANGLE CONTROLLER

Thank you for choosing **ENDA EPAC3-W-F** Phase Angle Vibration Controller.

- ▶ Control with phase angle technology.
- ▶ 4A AC or 15A AC load current (specify at order).
- ▶ 110V AC or 220V AC load voltage selection.
- ▶ 50Hz or 100Hz vibration frequency selection.
- ▶ Phase angle can be controlled by adjustment knob or 0-10V DC analog signal.
- ▶ Load output can be terminated via digital input.
- ▶ Digital input selection (used for NO/NC contact or NO/NC sensor).
- ▶ Power cable with plug and motor connection cable included.
- ▶ Connection cable for digital input (optional / specify at order).
- ▶ Maximum and minimum value can be assigned to output.
- ▶ Internal fuse.
- ▶ 4 Digits LED indicator.
- ▶ Control via phase angle.
- ▶ Soft Start feature.
- ▶ Varistor protection for voltage peaks.
- ▶ On/Off Power switch.
- ▶ CE marked according to European Norms.



## ORDER CODE

**EPAC3-W-F-S-15**

### Product Basic Code

Wall Mounted  
Vibration Frequency Selectable  
Phase Angle Controller

### Load Current (Specify at Order)

- 4A AC  
15 15AAC

### Digital Input Connection Cable (Optional / Specify at Order)

- N/A  
S Included

**R<sup>HS</sup>**  
**Compliant**



## ENVIRONMENTAL CONDITIONS

Ambient/Storage Temperature	0 ... +50°C/-25 ... +60°C (Must be no icing and no condensation in the environment)
Relative Humidity	Relative humidity 80% for temperatures up to -31°C decreasing linearly to 50% relative humidity at +40°C. (Must be no condensation in the environment).
Pollution Degree	2
Overvoltage Category	II
Height	Max. 2000m
Protection Class	According to EN60529 : IP20

**⚠ KEEP AWAY device from exposed to corrosive, volatile and flammable gases or liquids and DO NOT USE the device in similar hazardous locations.**

## OUTPUT

Load Current, AC51/25°C (Arms)	4A AC or 15A AC (specify at order)
Load Voltage (Vrms)	110V AC or 220V AC. Can be set by internal jumper (J1).
Vibration Frequency (Hz)	50/60Hz or 100/120Hz. Can be set by internal jumper (J1).
Overload Current $t=1s/25^{\circ}C$ (Arms)	150
Nonrecurrent Surge Current/25°C (Arms)	400
Voltage Drop in Transmission (Vrms)	1,6
Leakage Current (mArms)	5
I <sup>2</sup> t Value for Fuse $t=10ms$ (A <sup>2</sup> s)	880
Frequency (Hz)	50 - 60
Power Factor (CosØ)	>0,75
Minimum Operating Current (mArms)	160

## CONTROL

Control Type	Phase Angle controlled by using Adjustment Knob or 0-10V DC Analog Input Signal.
--------------	--

## DIGITAL INPUT

Input Type	Load output stopping method can be selected from program. (NO/NC contact or NO/NC sensor). Internal 12V DC output or an external 10-30V DC supply can be used.
------------	--

## GENERAL

Order Code	EPAC3-W-F
Supply	90-250V AC, 50/60Hz, 600VA
Dimensions	W80xH175xD60mm.
Weight	Approx. 400g (After packing).
Insulation Voltage	2500 Vrms 1 minute between input and output terminals.
Connection	2.5mm <sup>2</sup> screw-terminal connections.
Connection Screw Tightening Torques	Max. 0,5Nm
Product Standard	EN 60947-4-3
Mounting	Wall mounted.
Enclosure Materials	Self extinguishing plastics. (V-0 According to EN 60695-11-10 Standards).

**⚠ Avoid any liquid contact when the device is switched on. DO NOT clean the device with solvent (thinner, gasoline, acid etc.) and / or abrasive cleaning agents.**



SİSEL MÜHENDİSLİK ELEKTRONİK SAN. VE TİC. A.Ş.  
Sarıfelli Mah. Barbaros Cad. No:18 Y.Dudullu 34775  
ÜMRANİYE/İSTANBUL-TURKEY  
Tel : +90 216 499 46 64 Pbx. Fax : +90 216 365 74 01  
url : www.enda.com.tr



EPAC3-W-F-EN-01-190218



ENDA EPAC3-W-F Series devices are intended for wall-mounted installations. Make sure that the device is used only for intended purpose. The electrical connections must be carried out by a qualified staff and must be according to the relevant locally applicable regulations. During an installation, all of the cables that are connected to the device must be free of electrical power. The device must be protected against inadmissible humidity, vibrations, severe soiling and make sure that the operation temperature is not exceeded. The cables should not be close to the power cables or components.

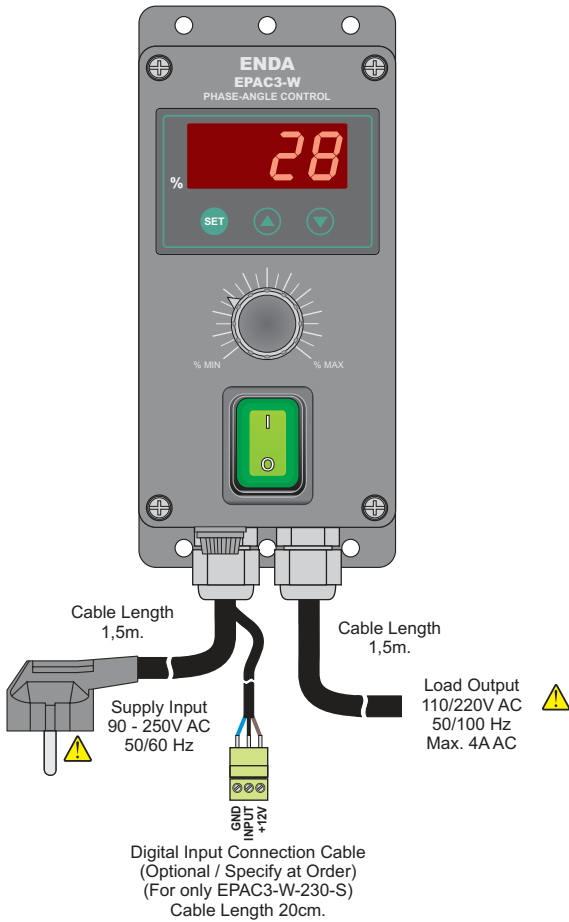

220V AC / 100-120Hz Vibration Frequency Selection

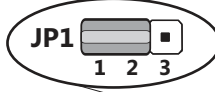

110V AC / 50-60Hz Vibration Frequency Selection

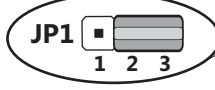

Cable connections can be performed on terminals by removing the front panel.

Holding screw for terminals 0.4-0.5Nm

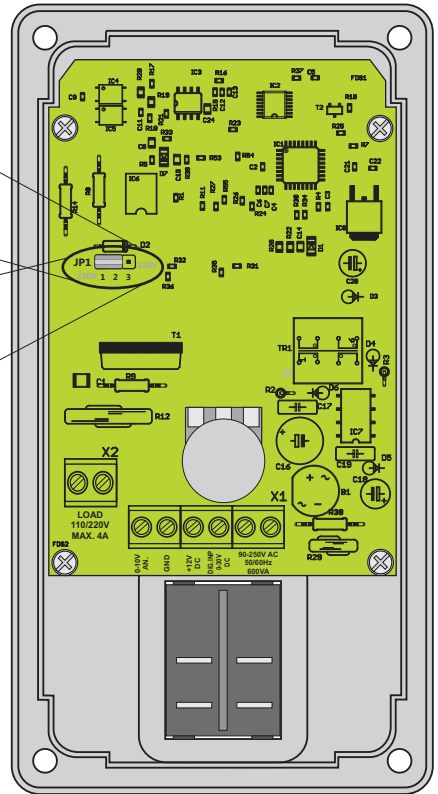

DIMENSIONS

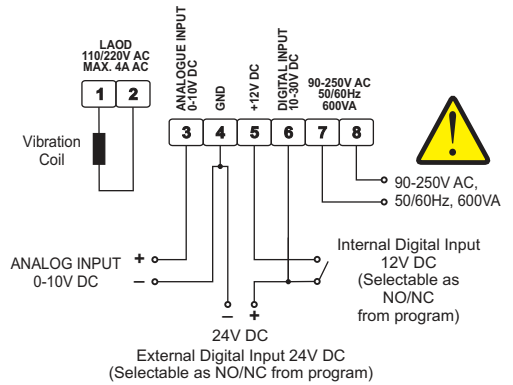
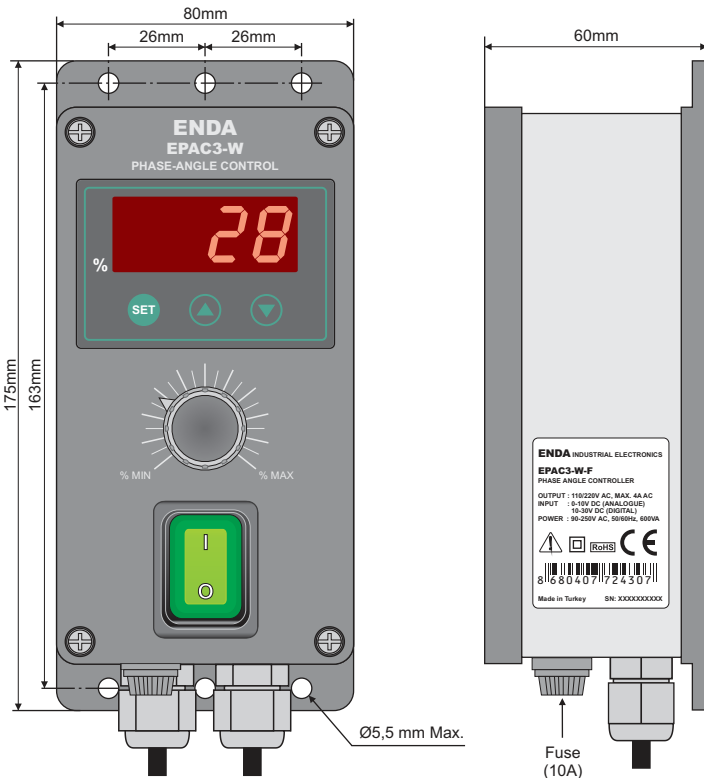

**ENDA INDUSTRIAL ELECTRONICS**  
**EPAC3-W-F**  
 PHASE ANGLE CONTROLLER

OUTPUT : 110/220V AC, MAX. 4A AC  
 INPUT : 0-10V DC (ANALOGUE)  
 10-30V DC (DIGITAL)  
 POWER : 90-250V AC, 50/60Hz, 600VA

8 680407 724307

Made in Turkey SN: XXXXXXXXXX

**ENDA INDUSTRIAL ELECTRONICS**  
**EPAC3-W-F-15**  
 PHASE ANGLE CONTROLLER

OUTPUT : 110/220V AC, MAX. 15A AC  
 INPUT : 0-10V DC (ANALOGUE)  
 10-30V DC (DIGITAL)  
 POWER : 90-250V AC, 50/60Hz, 600VA

8 680407 724345

Made in Turkey SN: XXXXXXXXXX

**Mounting** : Installation should be performed by using screw holes on the box.

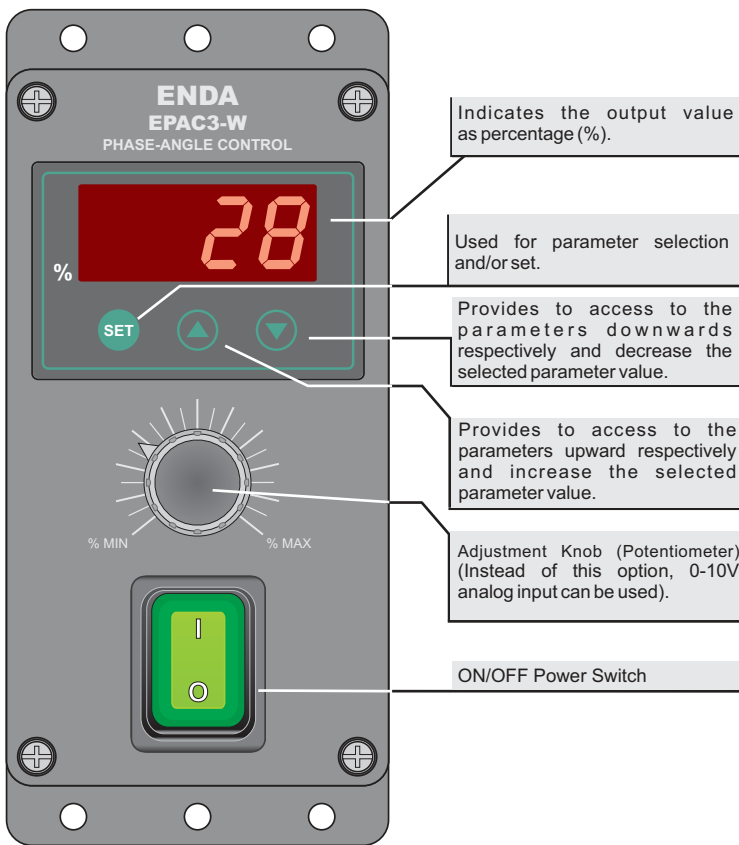

Indicates the output value as percentage (%).

Used for parameter selection and/or set.

Provides to access to the parameters downwards respectively and decrease the selected parameter value.

Provides to access to the parameters upward respectively and increase the selected parameter value.

Adjustment Knob (Potentiometer) (Instead of this option, 0-10V analog input can be used).

ON/OFF Power Switch

### Control with Phase Angle Vibration Frequency : 50Hz

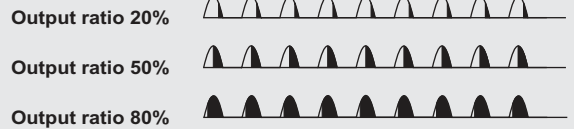

### Vibration Frequency: 100Hz

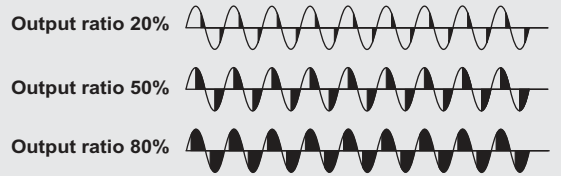

It is a proportional control method with uninterrupted power that used in inductive and variable resistive loads ( $\cos\phi < 1$ ). Disadvantage of this method is that it causes high electrical noises.

### Soft Start

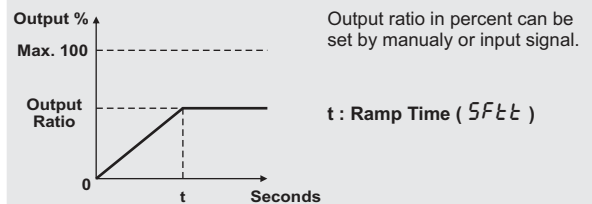

### Setting Parameters

If **SET** key is pressed, selected parameter can be adjusted to the desired value by using **↓** **↑** keys. After this process, if **SET** key is pressed, new parameter saved.



If **↓** or **↑** key is held down continuously, parameter value changes quickly.

### Factory Defaults

If **↓** key is hold down while the device is powered up, **dPPr** message appears on display and factory parameters restored.

### Locking and Unlocking Keypad

In "Running Mode", if **SET** key is hold down for 3 seconds, **Lac** message is displayed and the keypad will be locked. In order to unlocking keypad, hold down **SET** key for 3 seconds again, **unL** message appears on display and keypad will be unlocked. While keypad locked and any key is pressed, **Lac** message appears on display.

During "Running Mode", if **↑** **↓** keys are pressed together for 3 seconds, "Programming Mode" is entered. If no key is pressed within 10 seconds or by pressing **↑** **↓** keys together during "Programming Mode", the data is stored automatically and the "Running Mode" is entered.

### Programming Mode

