



Read this document carefully before using this device. The guarantee will be expired by device damages if you don't attend to the directions in the user manual. Also we don't accept any compensations for personal injury, material damage or capital

ENDA ET SERIES PID TEMPERATURE CONTROLLER

Thank you for choosing ENDA ET SERIES PID temperature controller.

- ▶ Selectable dual setpoint.
- ▶ Selectable thermocouple types.
- ▶ Automatic calculation of PID parameters (SELFTUNE).

⚠ Selftune for automatic PID calculation or manually enter PID parameters if known.

- ▶ Three different specifications can be assigned to digital input.
- ▶ Three different specifications can be assigned to F function key.
- ▶ Soft-Start feature.
- ▶ Selectable SSR control output.
- ▶ C/A2 Relay output programmable as secondary alarm or control output.
- ▶ A1 Relay output programmable as primary alarm or PID cooling output.
- ▶ Selectable heating/cooling control.
- ▶ Zero point input shift.
- ▶ In case of sensor failure, manually, periodical or auto-periodical control can be selected.
- ▶ RS485 ModBus protocol communication feature (optional).
- ▶ CE marked according to European Norms.

Order Code : ET

4	2	0	-	-	-
1	2	3			

1 - Size 4420.....48x48x87mm 7420.....72x72x97mm 8420.....48x96x87mm 9420.....96x96x50mm	2 - Supply Voltage UV.....90-250V AC LV.....10-30V DC / 8-24V AC	3 - Modbus RS... Modbus (Specify at order)
---	--	--

CE
RoHS
Compliant

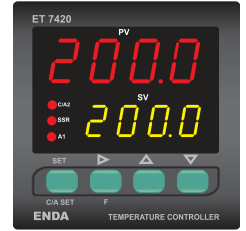

Input Type		Temperature Range		Accuracy
		°C	°F	
PT100 Resistance thermometer	EN 60751	-199.9...600.0 °C	-199.9...999.9 °F	± 0,2% (of full scale) ± 1 digit
PT100 Resistance thermometer	EN 60751	-200...600 °C	-328...1112 °F	± 0,2% (of full scale) ± 1 digit
J (Fe-CuNi) Thermocouple	EN 60584	-30.0...600.0 °C	-22.0...999.9 °F	± 0,5% (of full scale) ± 1 digit
J (Fe-CuNi) Thermocouple	EN 60584	-30...600 °C	-22...1112 °F	± 0,5% (of full scale) ± 1 digit
K (NiCr-Ni) Thermocouple	EN 60584	-30.0...999.9 °C	-22.0...999.9 °F	± 0,5% (of full scale) ± 1 digit
K (NiCr-Ni) Thermocouple	EN 60584	-30...1300 °C	-22...2372 °F	± 0,5% (of full scale) ± 1 digit
L (Fe-CuNi) Thermocouple	DIN 43710	-30.0...600.0 °C	-22.0...999.9 °F	± 0,5% (of full scale) ± 1 digit
L (Fe-CuNi) Thermocouple	DIN 43710	-30...600 °C	-22...1112 °F	± 0,5% (of full scale) ± 1 digit
T (Cu-CuNi) Thermocouple	EN 60584	-30.0...400.0 °C	-22.0...752.0 °F	± 0,5% (of full scale) ± 1 digit
T (Cu-CuNi) Thermocouple	EN 60584	-30...400 °C	-22...752 °F	± 0,5% (of full scale) ± 1 digit
S (Pt10Rh-Pt) Thermocouple	EN 60584	-40...1700 °C	-40...3092 °F	± 0,5% (of full scale) ± 1 digit
R (Pt13Rh-Pt) Thermocouple	EN 60584	-40...1700 °C	-40...3092 °F	± 0,5% (of full scale) ± 1 digit
B (Pt30Rh-Pt6Rh) Thermocouple	EN 60584	200...1700 °C	392...3092 °F	± 0,5% (of full scale) ± 1 digit

ENVIRONMENTAL CONDITIONS	
Ambient/storage temperature	0 ... +50°C/-25... +70°C (with no icing)
Max. Relative humidity	Relative humidity 80% for temperatures up to 31°C decreasing linearly to 50% relative humidity at 40°C.
Rated pollution degree	According to EN 60529 Front panel : IP65, Rear panel : IP20
Height	Max. 2000m

⚠ Do not use the device in locations subject to corrosive and flammable gases.

ELECTRICAL CHARACTERISTICS	
Supply	90-250V AC 50/60Hz, 10-30V DC / 8-24V AC SMPS
Power consumption	Max. 5VA
Wiring	Power connector: 2.5mm ² screw-terminal, Signal connector: 1,5mm ² screw-terminal connection.
Line resistance	Max. 100ohm
Data retention	EEPROM (minimum 10 years)
EMC	EN 61326-1: 2013
Safety requirements	EN 61010-1: 2010 (Pollution degree 2, overvoltage category II)

OUTPUTS	
C/A2 output	Relay : 250V AC, 8A (for resistive load), Selectable as NO+NC Control or Alarm2 output.
A1 output	Relay : 250V AC, 8A (for resistive load), NO (Selectable as Alarm1 and Cooling Control output).
SSR output	Max 20mA 24Volt
Life expectancy for relay	Mechanical 30.000.000; Electrical 100.000 operation. 250V AC, 8A (resistive load).

CONTROL	
Control type	Single set-point and alarm control
Control algorithm	On-Off / P, PI, PD, PID (selectable)
A/D converter	12 bit
Sampling time	100ms
Proportional band	Adjustable between 0% and 100%. If Pb=0.0%, On-Off control is selected.
Control period	Adjustable between 1 and 125 seconds
Hysteresis	Adjustable between 1 and 50°C/F
Output power	The ratio of power at a set point can be adjusted between 0% and 100%

HOUSING	
Housing type	Suitable for flush-panel mounting according to DIN 43 700.
Dimensions	ET4420 : G48XY48XD87MM ET7420 : G72XY72XD97MM ET8420 : G48XY96XD87MM ET9420 : G96XY96XD50MM
Weight	Approx. 400g after packing (250g for ET4420).
Enclosure material	Self extinguishing plastics.

⚠ While cleaning the device, solvents (thinner, gasoline, acid etc.) or corrosive materials must not be used.

Entering from the "Programming Mode" to the "Running Mode" :
If no key is pressed within 20 seconds during "Programming Mode", the data is stored automatically and the "Running Mode" is entered.

Alternatively, the same function occurs first pressing key is pressing "Programming Mode" is entered. Then keys are pressing together, data is recorded and "Running mode" is entered.

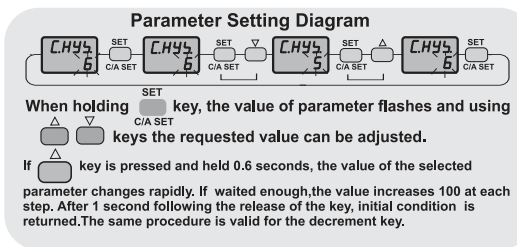
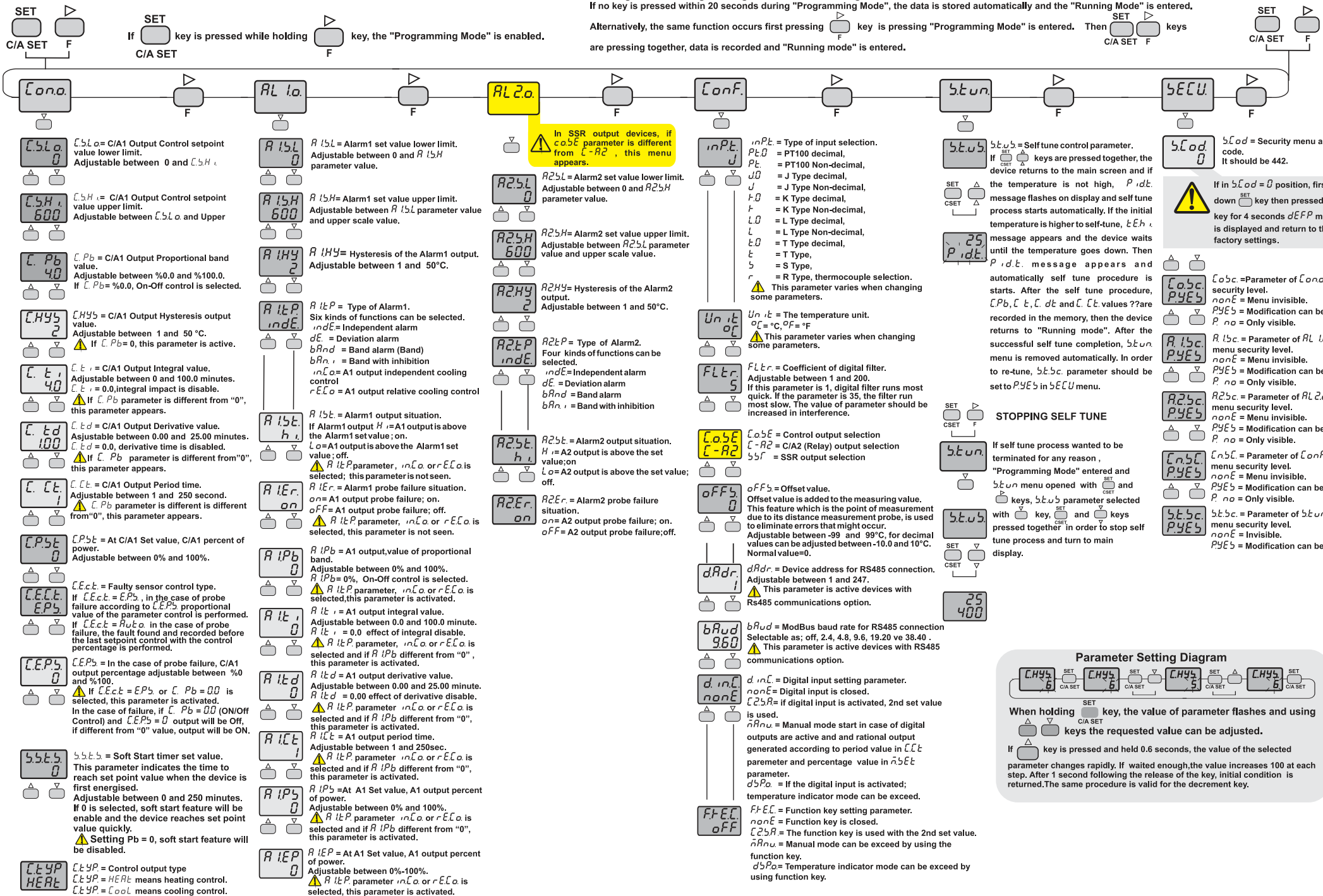

CONNECTION DIAGRAM

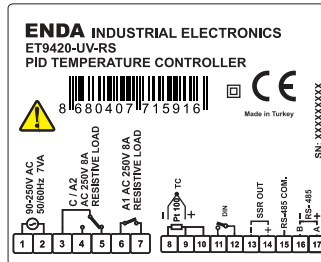
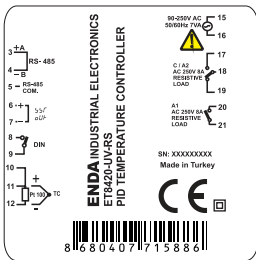
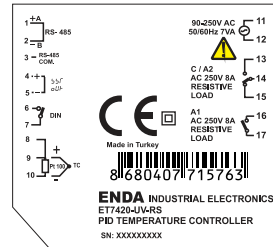
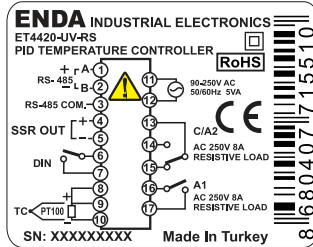
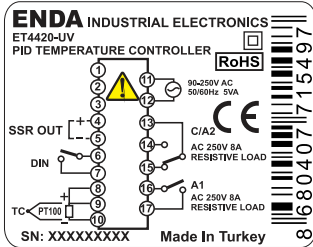

NOTE :

SUPPLY VOLTAGE

90-250V AC
or
10-30V DC /
8-24V AC
50/60Hz 7VA

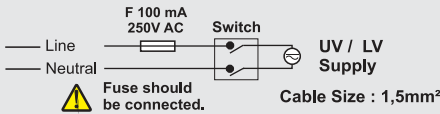
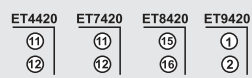

Holding screw
0,4-0,5Nm



Equipment is protected throughout
by DOUBLE INSULATION.



Logic output of the instrument is not electrically insulated from the internal circuits. Therefore, when using a grounding thermocouple, do not connect the logic output terminals to the ground.

SENSOR INPUT:

For J - K - T - S and R Thermocouples :
Use the correct compensating cable.
Do not make any supplement to cables. Connect the thermocouple cables to the right places at the input terminal.

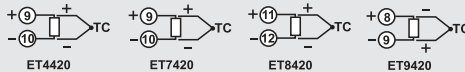

For resistance (PT100) Sensor :

When using 2-wire PT100 sensor, as shown in the figures, make 8 and 9 terminals short circuit for ET4420, ET7420 and ET9420 devices, make 10 and 11 terminals short circuit for ET8420 devices.

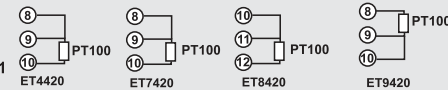

Note :

- 1) Mains supply cords shall meet the requirements of IEC 60227 or IEC 60245.
- 2) In accordance with the safety regulations, the power supply switch shall bring the identification of the relevant instrument and it should be easily accessible by the operator.

Please see page 7 for Modbus Connection Diagram

ALARM1 AND ALARM2 OUTPUT TYPES

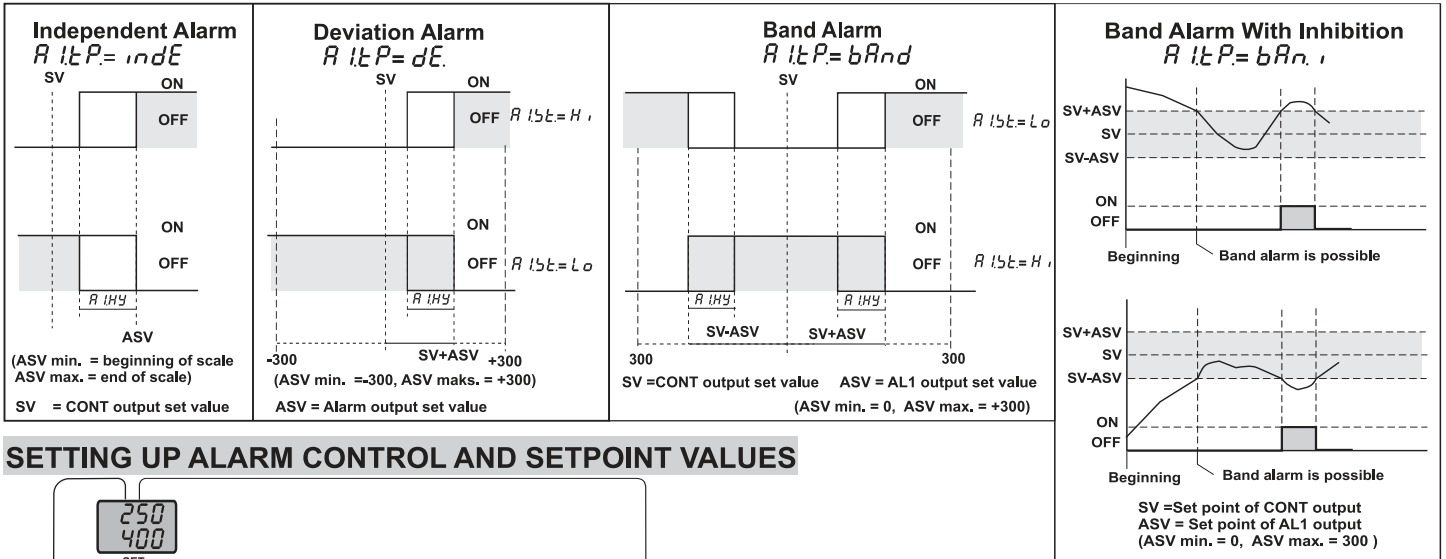

SETTING UP ALARM CONTROL AND SETPOINT VALUES

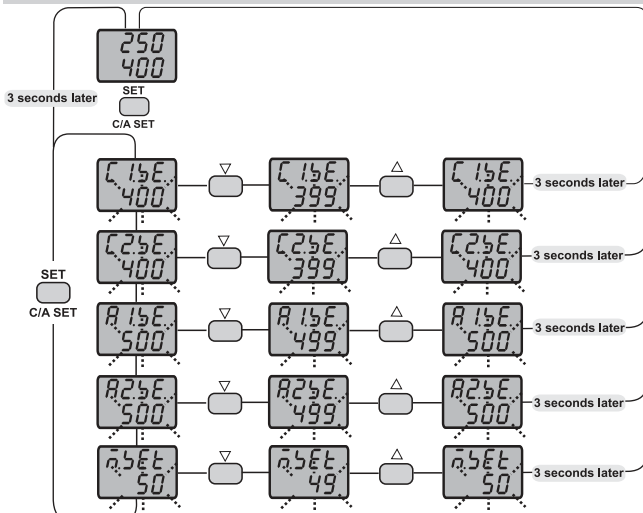

If one of the d_{inc} or $F.F.ec$ parameters are set to the C_{25R} value, this parameter is seen.

If the C_{05E} parameter is set to SSR out, this parameter is seen.

If one of the d_{inc} or $F.F.ec$ parameters are set to the n_{ANu} value and if C_{Pb} is different from 0, this parameter is seen.

ERROR MESSAGES

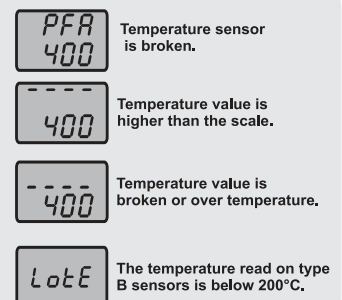

DIMENSIONS

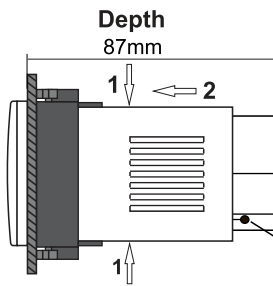
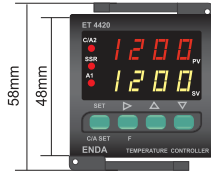

To removing the device from the panel :
- Push both sides in direction 1 and move the device in direction 2

Connection Cables

Flush mounting clamp
Panel

Ambient temperature sensor

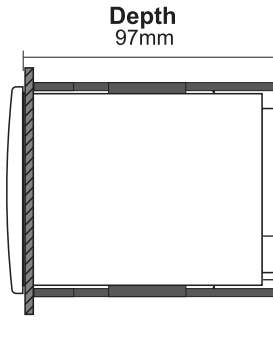
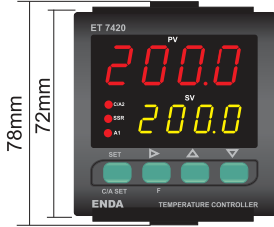

To removing the device from the panel :
- Pull up the clamping kit in direction 1 and move the clamping kit in direction 2

Connection Cables

Flush mounting clamp
Panel

Gasket

Ambient temperature sensor

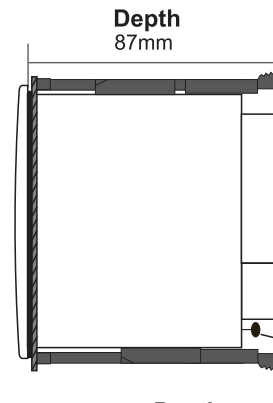
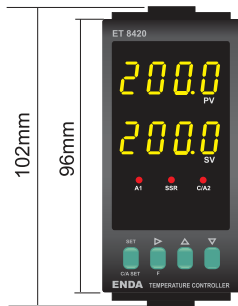

To removing the device from the panel :
- Pull up the clamping kit in direction 1 and move the clamping kit in direction 2

Connection Cables

Flush mounting clamp
Panel

Gasket

Ambient temperature sensor

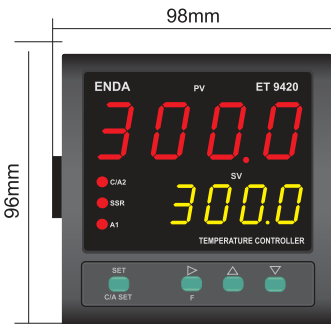

To removing the device from the panel :
- Push the clamping kit in direction 1 sideways and move the clamping kit in direction 2

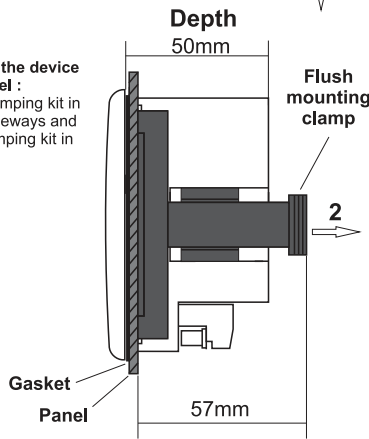

Flush mounting clamp

Gasket
Panel



ENDA ETx420 Series PID Temperature Controllers are intended for installation in control panels. Make sure that the device is used only for intended purpose.

The shielding must be grounded on the instrument side. During an installation all of the cables that are connected to the device must be free of energy. Device must be protected against inadmissible humidity, vibrations, severe soiling and make sure that the operation temperature is not exceeded. All input and output lines that are not connected to the supply network must be laid out as shielded and twisted cables. These cables should not be close to the power cables or components. The installation and electrical connections must be carried on by a qualified staff and must be according to the relevant locally applicable regulations.

PANEL CUT-OUT

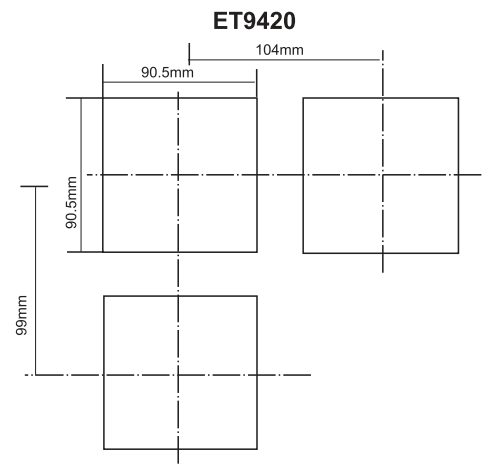
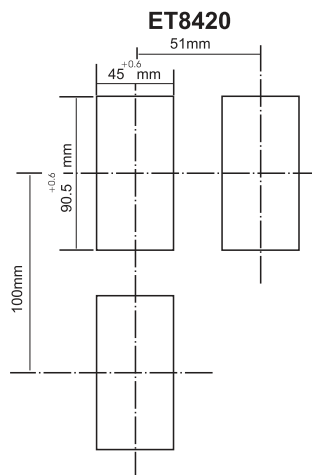
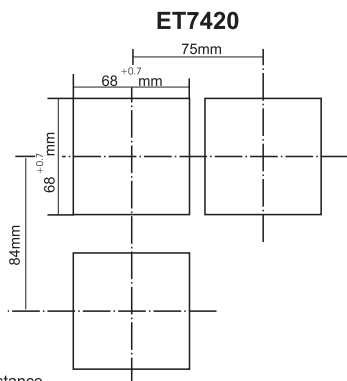
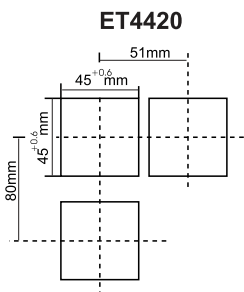

Note :



- 1) While panel mounting, additional distance required for connection cables should be considered (except ET9420).
- 2) Panel thickness should be maximum 9mm for ET4420, 10mm for ET7420, 8mm for ET8420 and 6mm for ET9420.
- 3) If there is no free space at back side of the device, it would be difficult to remove it from the panel. Required minimum free space; ET4420 = 100mm, ET8420 = 90mm, ET9420 = 60mm.

ENDA ET SERIES PID TEMPERATURE CONTROLLER MODBUS ADDRESS MAP

1.1 Memory Map for Holding Registers

	Parameter Number	Holding Register Addresses Desimal (Hex)	Data Type	Data Content	Read / Write Permission	Factory Defaults
Control Output Parameters	H0	0000d (0000h)	Word	Control output, temperature setpoint value	Read / Write	400
	H1	0001d (0001h)	Word	Control output, 2nd temperature setpoint value	Read / Write	400
	H2	0002d (0002h)	Word	Control output, minimum setpoint value	Read / Write	0
	H3	0003d (0003h)	Word	Control output, maximum setpoint value	Read / Write	600
	H4	0004d (0004h)	Word	Control output, proportional band setpoint value (Adjustable between %0.0 and %100.0)	Read / Write	4
	H5	0005d (0005h)	Word	Control output, hysteresis value (Adjustable between 1 and 50 °C or °F)	Read / Write	2
	H6	0006d (0006h)	Word	Control output, integral time (Adjustable between 0.1 and 100.0 minute)	Read / Write	40
	H7	0007d (0007h)	Word	Control output, derivative time (Adjustable between 0.01 and 10.00 minute)	Read / Write	100
	H8	0008d (0008h)	Word	Control output, time period setpoint value (Adjustable between 1 and 125 second)	Read / Write	20
	H9	0009d (0009h)	Word	Control output, set value power ratio (Adjustable between %0 and %100)	Read / Write	0
	H10	0010d (000Ah)	Word	Control output, set value power ratio in case of sensor failure (Adjustable between %0 and %100)	Read / Write	0
H11	0011d (000Bh)	Word	Control output, soft start value	Read / Write	0	
A1 Output Parameters	H12	0012d (000Ch)	Word	Alarm1 output temperature setpoint value	Read / Write	500
	H13	0013d (000Dh)	Word	Alarm1 output minimum setpoint value limit	Read / Write	0
	H14	0014d (000Eh)	Word	Alarm1 output maximum setpoint value limit	Read / Write	600
	H15	0015d (000Fh)	Word	Alarm1 output proportional band set value (Adjustable between %0.0 and %100.0)	Read / Write	0
	H16	0016d (0010h)	Word	Alarm1 output hysteresis value (Adjustable between 1 and 50 °C or °F)	Read / Write	2
	H17	0017d (0011h)	Word	Alarm1 output, integral time (Adjustable between 0.1 and 100.0 minute)	Read / Write	0
	H18	0018d (0012h)	Word	Alarm1 output, derivative time (Adjustable between 0.01 and 10.00 minute)	Read / Write	0
	H19	0019d (0013h)	Word	Alarm1 output, time period setpoint value (Adjustable between 1 and 125 second)	Read / Write	20
	H20	0020d (0014h)	Word	Alarm1 output, set value power ratio (Adjustable between %0 and %100)	Read / Write	0
	H21	0021d (0015h)	Word	Alarm1 output, set value power ratio in case of sensor failure (Adjustable between %0 and %100)	Read / Write	0
	H22	0022d (0016h)	Word	Alarm1 output type selection (Values can be given from 0 to 4) (0 = Independent alarm, 1 = Deviation alarm, 2 = Band alarm, 3 = Active alarm after in band time, 4 = Alarm1 output, cooling control selection)	Read / Write	0
A2 Output Parameters	H23	0023d (0017h)	Word	Alarm2 output, temperature setpoint value	Read / Write	500
	H24	0024d (0018h)	Word	Alarm2 output minimum setpoint value limit	Read / Write	0
	H25	0025d (0019h)	Word	Alarm2 output maximum setpoint value limit	Read / Write	600
	H26	0026d (001Ah)	Word	Alarm2 output, hysteresis value (Adjustable between 1 and 50 °C or °F)	Read / Write	2
	H27	0027d (001Bh)	Word	Alarm2 output type selection (Values can be given from 0 to 3) (0 = Independent alarm, 1 = Deviation alarm, 2 = Band alarm, 3 = Active alarm after in band time)	Read / Write	0
Configuration Parameters	H28	0028d (001Ch)	Word	Input selection number (0 = PT100 Decimal, 1 = Pt100 Non-decimal, 2 = J Decimal, 3 = J Non-decimal, 4 = K Decimal, 5 = K Non-decimal, 6 = L Decimal, 7 = L Non-decimal, 8 = T Decimal, 9 = T Non-decimal, 10= S Non-decimal, 11 = R Non-decimal.	Read / Write	5
	H29	0029d (001Dh)	Word	ModBus device address (Adjustable between 1 and 247)	Read / Write	1
	H30	0030d (001Eh)	Word	Modbus communication speed (Baudrate) (0 = Modbus cancel, 1 = 2400 bps, 2 = 4800 bps, 3 = 9600 bps, 4 = 19200 bps, 5 = 38400 bps)	Read / Write	3
	H31	0031d (001Fh)	Word	Digital filter coefficient (Adjustable between 1 and 200, 1 = filter is disable)	Read / Write	10
	H32	0032d (0020h)	Word	Control output, selection value (0 = C/A2 Control output selection, 1 = SSR Output)	Read / Write	0
	H33	0033d (0021h)	Word	Reserved	Read / Write	XX
	H34	0034d (0022h)	Word	Reserved	Read / Write	XX
	H35	0035d (0023h)	Word	Offset value	Read / Write	0
	H36	0036d (0024h)	Word	Function control parameter. (23040d (5A00h) self tune stops when this value is entered) (23041d (5A01h) self tune starts when this value is entered) (23042d (5A02h) returns to factory defaults when this value is entered)	Read / Write	0
	H37	0037d (0025h)	Word	Reserved	Read / Write	XX
	H38	0038d (0026h)	Word	Reserved	Read / Write	XX
	H39	0039d (0027h)	Word	Manual control output percentage (Adjustable between %0 and %100)	Read / Write	50

ENDA ET SERIES PID TEMPERATURE CONTROLLER MODBUS ADDRESS MAP

1.1 Memory Map for Holding Registers (continue)

Parameter Number	Holding Register Addresses	Data Type	Data Content	Read / Write Permission	Factory Defaults	
	Desimal (Hex)					
Configuration Parameters	H40	0040d (0028h)	Word	Digital input control parameter (0 = Digital input off, 1 = 2nd set value is selected with digital input, 2 = Manual mode is entered via digital input, 3 = Digital input is passed to display mode	Read / Write	0
	H41	0041d (0029h)	Word	Function key control parameter (0 = Function key off, 1 = 2nd Set value is selected with function key, 2 = Manual mode is entered via function key, 3 = With the function key display mode is entered)	Read / Write	0
	H42	0042d (008Ah)	Word	Reserved	Read / Write	XX
	H43	0043d (002Bh)	Word	Reserved	Read / Write	XX
	H44	0044d (002Ch)	Word	Reserved	Read / Write	XX
	H45	0045d (002Dh)	Word	Reserved	Read / Write	XX
	H46	0046d (002Eh)	Word	Reserved	Read / Write	XX
	H47	0047d (002Fh)	Word	Reserved	Read / Write	XX
	H48	0048d (0030h)	Word	Control output menu, security parameter (0 = Menu invisible, 1 = Menu programmable, 2 = Menu only visible)	Read / Write	1
	H49	0049d (0031h)	Word	Alarm1 output menu security parameter (0 = Menu invisible, 1 = Menu programmable, 2 = Menu only visible)	Read / Write	1
	H50	0050d (0032h)	Word	Alarm2 output menu, security parameter (0 = Menu invisible, 1 = Menu programmable, 2 = Menu only visible)	Read / Write	1
	H51	0051d (0033h)	Word	Configuration menu, security parameter (0 = Menu invisible, 1 = Menu programmable, 2 = Menu only visible)	Read / Write	1
	H52	0052d (0034h)	Word	Self tune menu, security parameter (0 = Menu invisible, 1 = Self tune can be done)	Read / Write	1

1.2 Memory Map for Coils

Parameter Number	Coil Addresses	Data Type	Data Content	Read / Write Permission	Factory Defaults
C0	(0000)h	Bit	Alarm2 Status (0 = Active Low ,1 =Active High)	Read / Write	1
C1	(0001)h	Bit	Alarm2 output position in case of Prob failure (0 = Off , 1 = On)	Read / Write	0
C2	(0002)h	Bit	Alarm1 Status (0 = Active Low ,1 =Active High)	Read / Write	1
C3	(0003)h	Bit	Alarm1 output position in case of Prob failure (0 = Off , 1 = On)	Read / Write	0
C4	(0004)h	Bit	Control output configuration (0 = Heat ; 1 = Cool)	Read / Write	0
C5	(0005)h	Bit	Temperature unit (0 = °C ; 1 = °F)	Read / Write	0
C6	(0006)h	Bit	Control outputs active (0 = Control outputs active, 1 = Only display mode)	Read / Write	0
C7	(0007)h	Bit	Controlling according to 2nd temperature setpoint (If C7 = 0 is H0, if C7 = 1 is H1)	Read / Write	0
C8	(0008)h	Bit	Auto/Manual selection (0 = Automatic "Running mode", 1 = Manual "Running mode". In this mode, output generated according to H39 parameter.)	Read / Write	0
C9	(0009)h	Bit	Control format in case of probe failure (0 = H10 proportional control according to percentage value, 1 = Error found before the setpoint control is done with the value of the proportional control)	Read / Write	0

1.3 Memory Map for Input Registers

Parameter Number	Input Register Addresses	Data Type	Data Content	Read / Write Permission
I0	0000d (0000h)	Word	Measured temperature	Read Only
I1	0001d (0001h)	Word	Percentage of analog output	Read Only
I2	0002d (0002h)	Word	Measurement error codes 0 = No error, 1 = Sensor disconnected or broken, 2 = Lower scale error, 3 = Upper scale error, 4 = PT100 short circuit or temperature too low, 5 = Wrong input selection	Read Only
I3	0003d (0003h)	Word	Self tune condition codes 0 = No error, 1 = Initial temperature is higher than 60% setpoint value, 2 = Calculating PID parameters, 3 = Calculating power set parameters	Read Only
I4	0004d (0004h)	Word	Current (active) temperature setpoint.	Read Only
I5	0005d (0005h)	Word	Reserved	Read Only
I6	0006d (0006h)	Word	Current (active) decimal point value (0 = No decimal point, 1 = 0.0 Decimal point is tenths)	Read Only

1.4 Memory Map for Software Revision Input Registers

Software Revision	61472d (F020h)	14 Word	Software name and update is read in ASCII format and as 14 word. Sample : ET4420-01 03 Dec 2013. Memory Formats : Word Word Word Word Word Word Word Word Word Word Word Word Word Word 1 2 3 4 5 6 7 8 9 10 11 12 13 14 TE44020-1 30DCE210.3	Read Only
NOTE : To view each word correctly by changing the byte sequences should be displayed as ASCII TEXT				

ENDA ET SERIES PID TEMPERATURE CONTROLLER MODBUS ADDRESS MAP

1.5 Memory Map for Discrete input

Parametre Numarası	Discrete Input Addresses	Data Type	Data Content	Read / Write Permission
D0	(0000)h	Bit	C/A2 Control output status (0 = OFF ,1 = ON)	Read Only
D1	(0001)h	Bit	A1 Output status (0 = OFF , 1 = ON)	Read Only
D2	(0002)h	Bit	SSR Output status (0 = OFF ,1 = ON)	Read Only
D3	(0003)h	Bit	Digital input status (0 = OFF ,1 = ON)	Read Only

2. MODBUS ERROR MESSAGES

Modbus protocol has two types error, communication error and operating error. Reason of the communication error is data corruption in transmission. Parity and CRC control should be done to prevent communication error. Receiver side checks parity and CRC of the data. If they are wrong, the message will be ignored. If format of the data is true but function doesn't perform for any reason, operating error occurs. Slave realizes error and sends error message. Most significant bit of function is changed '1' to indicate error in error message by slave. Error code is sent in data section. Master realizes error type via this message.

ModBus Error Codes

Error Code	Name	Meaning
01	ILLEGAL FUNCTION	The function code received in the query is not an allowable action for the slave. If a Poll Program Complete command was issued, this code indicates that no program function preceded it.
02	ILLEGAL DATA ADDRESS	The data address received in the query is not an allowable address for the slave.
03	ILLEGAL DATA VALUE	A value contained in the query data field is not an allowable value for the slave.

Message example;

Structure of command message (Byte Format)

Device Address		(0A)h
Function Code		(01)h
Beginning address of coils.	MSB	(04)h
	LSB	(A1)h
Number of coils (N)	MSB	(00)h
	LSB	(01)h
CRC DATA	LSB	(AC)h
	MSB	(63)h

Structure of response message (Byte Format)

Device Address		(0A)h
Function Code		(81)h
Error Code		(02)h
CRC DATA	LSB	(B0)h
	MSB	(53)h

As you see in command message, coil information of (4A1)h = 1185 is required but there isn't any coil with 1185 address. Therefore error code with number (02) (Illegal Data Address) sends.

