



Please read this document carefully before using this product. The guarantee will be invalidated if the device is damaged by not following instructions detailed in the manual. The company shall not be responsible for any damage or losses however caused, which may be experienced as a result of the installation or use of this product.

ENDA ET2413 CAR AIR CONDITIONER CONTROLLER

Thank you for choosing ENDA ET2413 Car Air Conditioner Controller.

- * 77 x 35 mm size.
- * 4 digit digital display.
- * Decimal display feature.
- * Three contact outputs for fan and climate control.
- * Fan and air conditioner control is done manually with the buttons on the front panel.
- * CE marked according to European standards.



Order Code : ET2413 -

1 - Supply Voltage
230.....230V AC

1

LV.....10-30V DC /
8-24V AC



Technical Specifications

ENVIRONMENTAL FEATURES

Ambient/storage Temperature	0 ... +50°C/-25 ... 70°C
Relative Humidity	It operates at 80% humidity up to 31°C, then decreases linearly to 50% at 40°C.
Protection Class	According to EN 60529 standard; Front panel : IP65 , Rear panel : IP20
Height	Max. 2000m.



Do not use the device in locations subject to corrosive and flammable gasses.

ELECTRICAL FEATURES

Supply Voltage	230V AC +%10 -%20, 50/60Hz , 10-30V DC / 8-24V AC SMPS
Power Consumption	Max. 5 VA
Connection	2.5mm ² screw-terminal connections.
Scale	-60.0°C...150.0°C
Sensitivity	± 0.1°C
Accuracy	± 1°C
EMC	EN 61326-1: 2013
Security Requirements	EN 61010-1: 2010 (Pollution degree 2, overvoltage category II)

OUTPUTS

FAN1	Relay: 250V AC, 8A (for resistive load), NO; 1/2 HP 240V AC CosΦ = 0.4 (for inductive load)
FAN2	Relay: 250V AC, 8A (for resistive load), NO+NC; 1/2 HP 240V AC CosΦ = 0.4 (for inductive load)
A/C(Air Conditioner)	Relay: 250V AC, 8A (for resistive load), NO; 1/2 HP 240V AC CosΦ = 0.4 (for inductive load)
Life Expectancy	No-load 30,000,000 switching; 100,000 switching at 250V AC, 8A resistive load.

HOUSING

Housing Type	Suitable for flush -panel mounting.
Dimensions	W77xH35xD61mm
Weight	Approx. 190g (After packing).
Enclosure Material	Self-extinguishing plastics are used.



While cleaning the device, solvents (thinner, benzene, acid etc.) or corrosive materials must not be used.



Air conditioning (A/C) led. If the air conditioner is on, this led lights up.

- Increase Key** ▲ As this button is pressed, all the fans are activated respectively. If no fan is active, first **FAN1** becomes active and **FAN1** led lights up. When pressed once more, **FAN2** is activated and **FAN2** led turns on.
- Decrease Key** ▼ As this button is pressed, the fans and leds are disabled respectively. When both fans are active, pressing this button once turns off the **FAN2** and **FAN2** leds. When pressed once again, **FAN1** and **FAN1** leds are also disabled.
- A/C Key** ■ When this button is pressed, the relay controlling the **A/C** (Air Conditioner) becomes active if it is not active and the **A/C** led lights up, if it is active, it becomes passive and the **A/C** led goes off.

Fan leds. The right led indicates whether **FAN1** is active, and the left led indicates whether **FAN2** is active.

Note: If one of the following error conditions occurs in the device, all outputs and leds become passive.

Error Status Messages

PFR Indicates that the thermostat probe is broken.

P5C Indicates that the thermostat probe is short-circuited.

--- Indicates that the measurement value has exceeded the upper scale.

--- Indicates that the measurement value has fallen below the lower scale.

Dimensions



To remove the device from the panel:

- Push the clamping tool in direction 1 to the side.
- Pull the clamping tool in 2 direction.

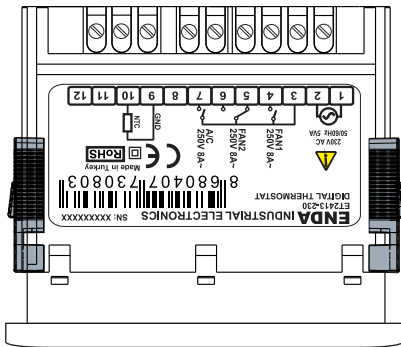
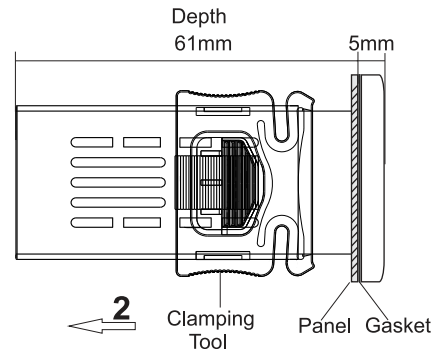

Compression Device

Panel slot section

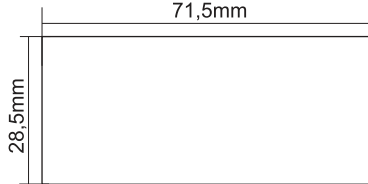

Note : 1) Panel thickness can be 7mm at most.

2) If there is no space of at least 60mm behind the device, it will be difficult to remove it from the panel.

NOTE :

SUPPLY

184-253V AC
50/60Hz 5VA
or
10-30V DC /
8-24VAC
50/60Hz 5VA

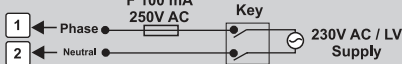

1) Device cables must comply with IEC 60227 or IEC 60245 requirements.

2) In accordance with the security rules, the mains switch must be in a position that the operator can easily reach and there must be a sign indicating that the switch is related to the device.

⚠ Fuse must be used.

Cable cross section: 1.5mm²

Connection Diagram



ENDA ET2413 is a panel type controller. The device must be used in accordance with the instructions. Installation and electrical connections must be made by technical personnel in accordance with the instructions in the user manual. There should be no electricity in the connecting cables during assembly. The device must be protected from moisture, vibration and pollution. Attention should be paid to the operating temperature. Assembly cables should not be routed near high power lines and devices.

