



Read this document carefully before using this device. The guarantee will be expired by device damages if you don't attend to the directions in the user manual. Also we don't accept any compensations for personal injury, material damage or capital disadvantages.

ENDA ET2001 ON/OFF TEMPERATURE CONTROLLER

Thank you for choosing ENDA ET2001 temperature controller.

- * 77 x 35mm sized.
- * J Sensor input types.
- * Zero point input shift.
- * C1 Relay out for temperature control.
- * When C1 output configuration is selected for cooling, compressor delay time can be entered.
- * Selectable heating / cooling control.
- * In case of sensor failure, relay state can be configured as ON or OFF.
- * CE marked according to European Norms.



CE **RoHS**
Compliant

Order Code : ET2001J -

1	2	3

1 - Supply Voltage 230.....230V AC LV..... 10-30V DC / 8-24V AC	2- Input J.....Thermokupl
--	-------------------------------------

CONNECTION DIAGRAM



ENDA ET2001 is intended for installation within control panels. Make sure that the device is used only for intended purpose. The shielding must be grounded on the instrument side. During an installation, all of the cables that are connected to the device must be free of electrical power. The device must be protected against inadmissible humidity, vibrations, severe soiling. Make sure that the operation temperature is not exceeded. All input and output lines that are not connected to the supply network must be laid out as shielded and twisted cables. These cables should not be close to the power cables or components. The installation and electrical connections must be carried out by a qualified staff and must be according to the relevant locally applicable regulations.

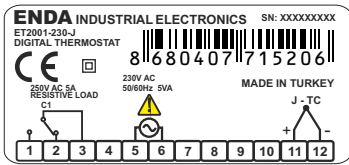

Equipment is protected throughout by **DOUBLE INSULATION**

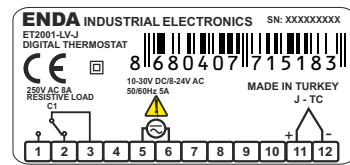

Holding screw
0.4-0.5Nm.

NOTE : SUPPLY:

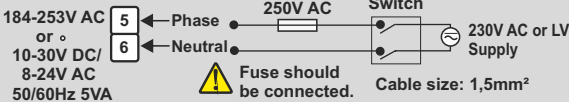

- Note
- 1) Mains supply cords shall meet the requirements of IEC 60227 or IEC 60245.
 - 2) In accordance with the safety regulations, the power supply switch shall bring the identification of the relevant instrument and it should be easily accessible by the operator.

SİSEL MÜHENDİSLİK ELEKTRONİK SAN. VE TİC. A.Ş.
Şerifali Mah. Barbaros Cad. No:18 Y.Dudullu 34775
ÜMRANIYE/İSTANBUL-TURKEY
Tel : +90 216 499 46 64 Pbx. Fax : +90 216 365 74 01
url : www.enda.com.tr

ENDA™

TECHNICAL SPECIFICATIONS

		INPUT	Accuracy
Input Type	Scale Range		
J (FeCuNi) Thermocouple	EN 60751	-30.0...400.0 °C	± 1% (for full scale) ± 1 Digit

ENVIRONMENTAL CONDITIONS

Ambient/Storage temperature	0 ... +50 / °C -25... +70 °C
Relative Humidity	Max. humidity 80% for temperatures up to 31°C decreasing linearly to 50% relative humidity at 40°C.
Protection Class	According to EN60529; Front panel: IP65 Rear panel : IP20
Height	Max. 2000m

Do not use the device in locations subject to corrosive and flammable gasses.

ELECTRICAL CHARACTERISTICS

Supply	230V AC +%-10-%20 50/60Hz ;10-30V DC / 8-24V AC SMPS
Power Consumption	Max. 3VA
Wiring	Power connector : 2.5mm² screw-terminal, Signal connector : 1.5mm² screw-terminal conenction.
Line Resistance	Max. 100ohm
Data Retention	EEPROM (Min. 10 years)
EMC	EN 61326-1: 2013 (Performance criterion B is satisfied for EN 61000-4-3)
Safety Requirements	EN 61010-1: 2010 (Pollution degree 2, overvoltage category II)
Indicator	4 digits, 12.5mm, 7 segment red LED

OUTPUT

C1 Output	For 8A Models : 250V AC, 8A (for resistive load), NO and NC control output.
-----------	---

Life Expectancy for Relay	For 8A Models : 30.000.000 Switching for no-load operation; 300.000 switching for 8A resistive load at 250VAC.
---------------------------	--

CONTROL

Control Type	Single-setpoint and alarm control.
Control Algorithm	On-Off Control.
A/D Converter	12 bit resolution, 100ms sampling time.
Hysteresis	Adjustable between 0.1 and 5.0°C/F.

HOUSING

Housing Type	Suitable for flush-panel mounting according to DIN 43 700.
Dimensions	W77xH35xD61mm
Weight	Approx. 215g (After packing)
Enclosure Materials	Self extinguishing plastics

While cleaning the device, solvents (thinner, benzene, acid etc.) or corrosive materials must not be used.

Dimensions

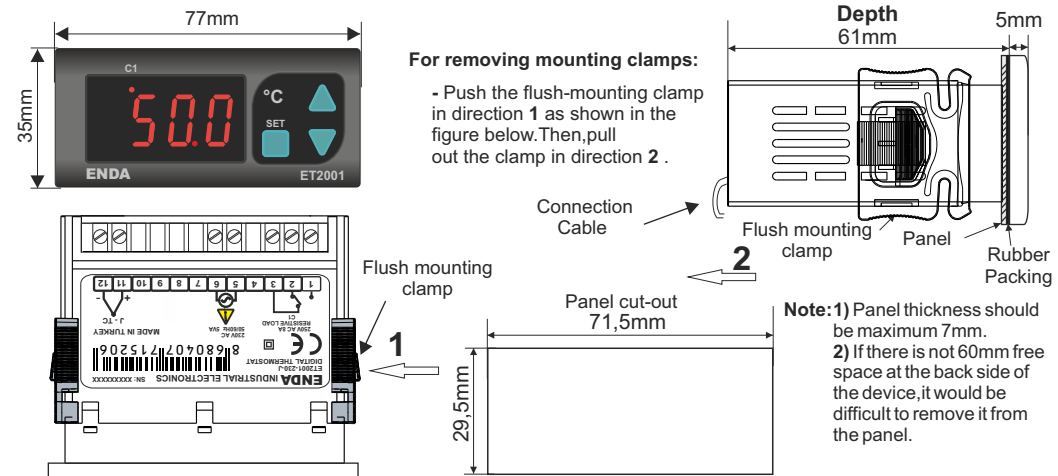

Programming Diagram

Running Mode

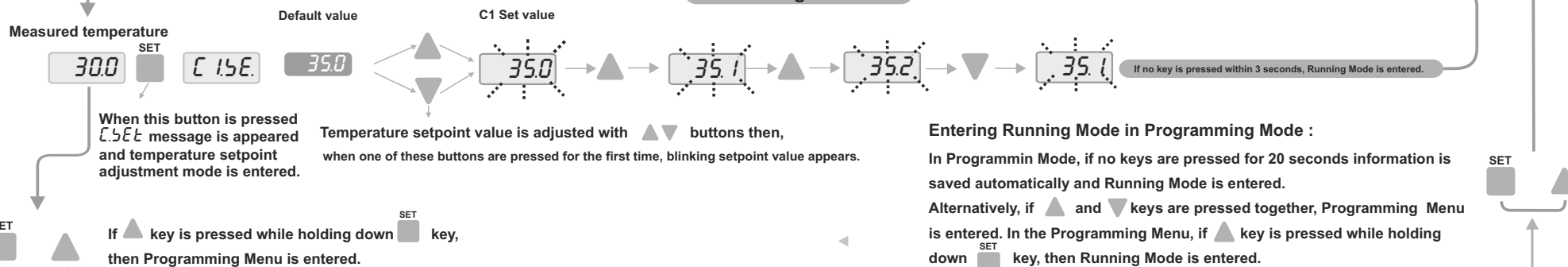

Programming Menu

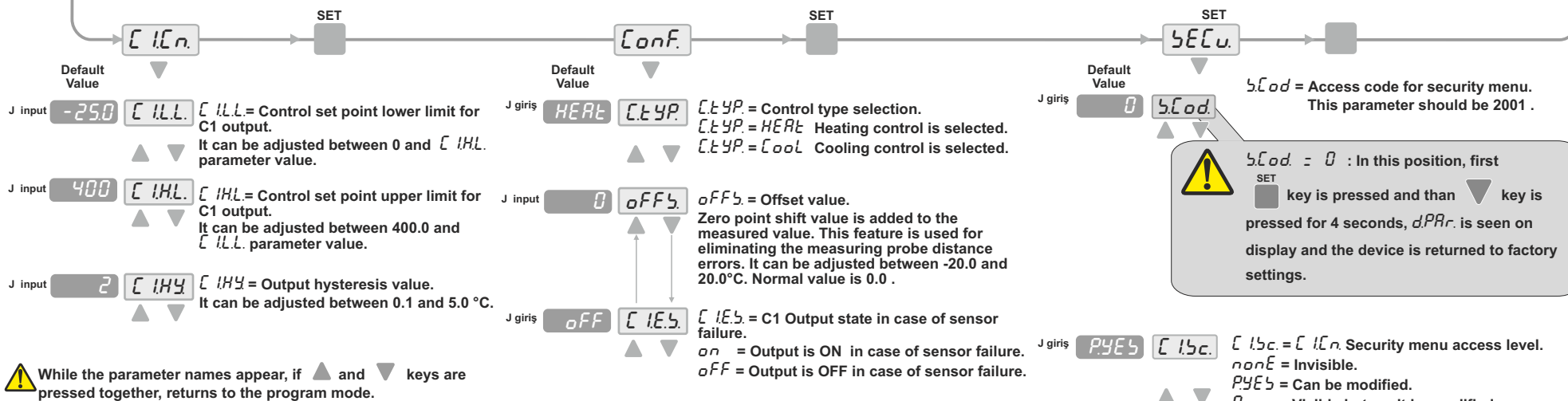

⚠ While the parameter names appear, if ▲ and ▼ keys are pressed together, returns to the program mode.

Modification Of Parameter Diagram

While holding down SET key, parameter value blinks and by using ▼ ▲ keys, the requested value can be adjusted.

If ▲ key is pressed and held 0.6 seconds, the value of the selected parameter increases rapidly. If waited enough, the value increases a hundred at each step. After 1 second, following the release of the key, initial increasing condition is returned. The same procedure is valid for the decrementing.

ERROR MESSAGES

PFR Sensor is broken

--- Temperature value is higher than the scale

--- Temperature value is lower than the scale