



Read this document carefully before using this device. The guarantee will be expired by device damages if you don't attend to the directions in user manual. Also we don't accept any compensations for personal injury, material damage or capital disadvantages.

ENDA EPPC02 PHASE SEQUENCE PROTECTION AND CONTROLLER RELAYS

Thank you for choosing **ENDA EPPC02** Rail mounted phase sequence protection and controller relays.

- Single and 3 Phase monitoring.
- Phase Failure monitoring.
- Phase Sequence monitoring.
- Adjustable Voltage protection.
- Overvoltage and/or Low Voltage protection.
- System control outputs (OUT & OUT2)
- Rail mounted, screw-terminal connection.
- CE marked according to European Norms.

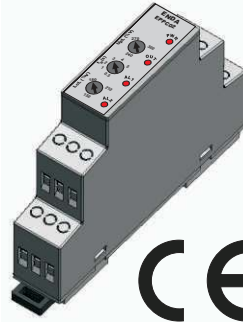

RoHS
Compliant



ORDER CODE : EPPC02

Technical Specifications

OPERATING		
ENDA voltage protection relays are designed to protect single or three-phase systems from overvoltage changes and phase sequence disturbances.		
1- Phase Failure	In case of the absence of at least one phase, the output relay will be switched OFF immediately.	
2- Phase Sequence	In case of wrong phase order, OUT relay will be switched OFF and the OUT2 relay will be switched ON immediately. OUT relay will be switched ON and the OUT2 relay will be switched OFF immediately when the phase order is corrected.	
3- Adjustable Voltage Protection	When the upper and lower limit values exceed, output relay status will be switched OFF at the end of the set delay time. Due to minor fluctuation changes in the mains voltage will be ignored. The system has 3% (6V) hysteresis protection for harmful conditions.	
4- Overvoltage and/or Lower Voltage Protection	If the nominal voltage of the input phase exceeds 40% (308V) and/or fall to 40% (132V), the output relay status will be OFF immediately. With the return to the normal operating voltage, output relay status will be ON immediately.	
⚠ Priority orders of alarm conditions : Phase failure, phase sequence, overvoltage, over low voltage, high voltage, and low voltage alarm.		
CONTROL		
Delay time (t_g) adjustment	0.1, 1, 2, 6, 8, 10 seconds can be selected on device.	
Voltage lower limit (LoL) adjutment	Can be selected on the device between -30% and +25% of nominal voltage.	
Voltage upper limit (UpL) adjutment	Can be selected on the device between -30% and +25% of nominal voltage.	
Hysteresis (V)	6 VAC.	
Overvoltage (V)	308 VAC.	
Low voltage (V)	132 VAC.	
ALARM CONDITIONS		
LEDx	LED Status	Description
PWR	ON	Device running
	OFF	Device not running
OUT	ON	Relay1 activated (energized)
	Flashing slowly	Relay2 activated (Phase sequence failure)
	OFF	Relays deactivated
AL1/AL2	AL1 OFF, AL2 ON	System running normally (No failure)
	AL1 ON, AL2 OFF	Low voltage
	AL1 OFF, AL2 ON	High voltage
	AL1 ON, AL2 ON	Low and High voltage
	AL1 Flashing slowly, AL2 OFF	Very low voltage
	AL1 OFF, AL2 Flashing slowly.	Very high voltage
	AL1 and AL2 Flashing quickly.	No Phase
	⚠	
1) During the status Led is lighting, delay time duration will be activated if the AL1 and/or AL2 Led(s) also lit. The output relay and the relay status Led will be switched OFF when the delay time is over.		
2) If the relay status Led flashes slowly, it indicates that the phase sequence is faulty and the 2nd relay is activated.		
3) OUT and OUT2 relays can not be switched ON at the same time. The voltage or other conditions applicable to OUT will also apply to OUT2.		

ELECTRICAL CHARACTERISTICS		
Supply voltage	125-410V AC +%10 -%10	
Operating frequency	45-65 Hz	
Power consumption	Max. 10VA.	
Connection	Screw-terminal connection.	
Reset time	Max. 0.01 seconds.	
Accuracy	Depending on the effect of voltage	: Max. %1
	Measurement error	: Max. %5
	Depending on the effect of temperature	: Max %1
EMC	EN 61326-1: 2013	
Safety requirements	EN 61010-1: 2010 (pollution degree 2, overvoltage category II)	
Insulation test voltage	3kV AC at 60 seconds (minimum). 4,2kV DC at 60 seconds (minimum).	
ENVIRONMENTAL CONDITIONS		
Ambient/storage temperature	0 ... +50°C/-25 ... +70°C (With no condensation and icing).	
Max. relative humidity	Max. humidity 80% for temperatures up to 31°C decreasing linearly to 50% relative humidity at 40°C. (With no condensation and icing).	
Rated pollution degree	IP20, According to EN 60529	
Height	Max. 2000m	
⚠ KEEP AWAY device from exposed to corrosive, volatile and flammable gases or liquids and DO NOT USE the device in similar hazardous locations.		
OUTPUTS		
Control output (OUT)	Relay : 250V AC, 10A (for resistive load), NO+NC	
Control output (OUT2)	Relay : 250V AC, 10A (for resistive load), NO+NC	
Life expectancy for relay	Without load 10.000.000 operation; 250V AC, 10A resistive load 50.000 operation.	
Control output state	OUT Led illuminates when the control output is energized. And the OUT Led also illuminated when the control output is energized and phase sequence failure (while in this state, OUT2 relay will switch ON).	
HOUSING		
Mounting	Rail mounted (EN 60715, Th35)	
Dimensions	W18xH84xD62mm	
Weight	Approx. 90g (after packaging)	
Enclosure material	Self extinguishing plastics.	
⚠ Avoid any liquid contact when the device is switched on. DO NOT clean the device with solvent (thinner, gasoline, acid etc.) and / or abrasive cleaning agents.		

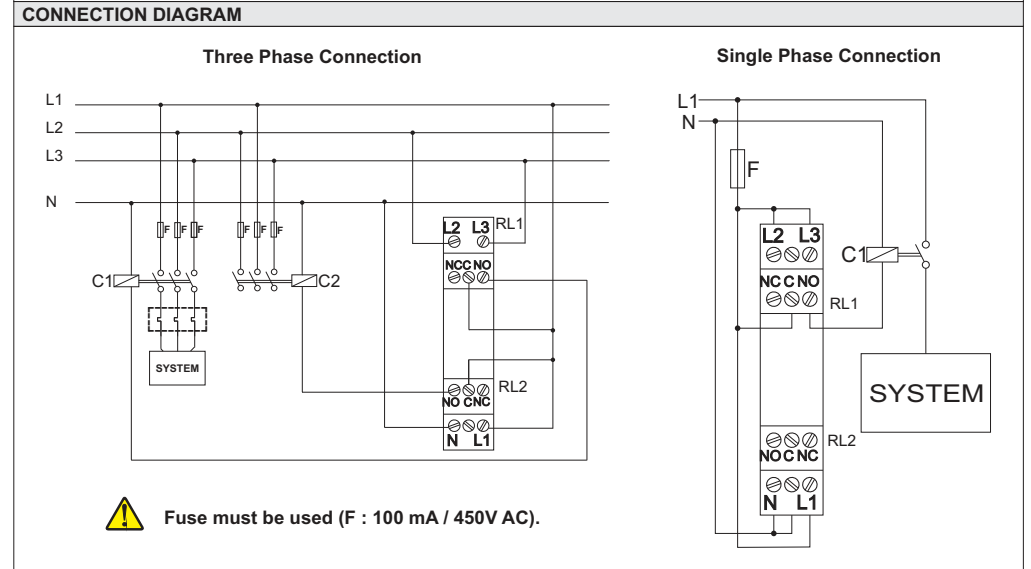

CONNECTION DIAGRAM

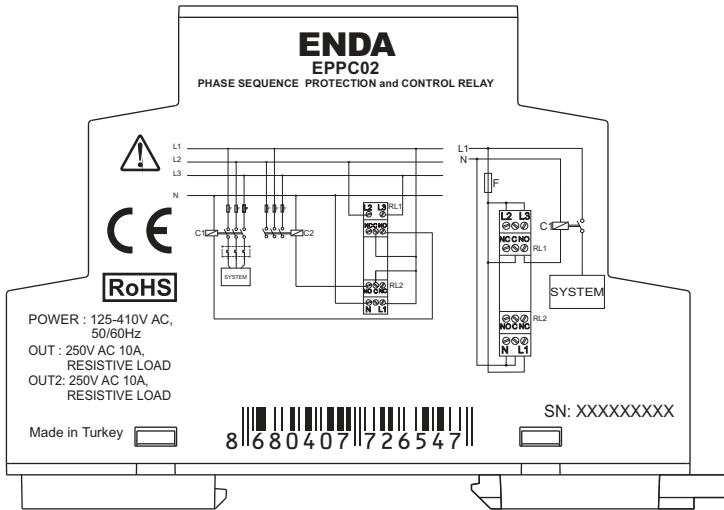

ENDA EPPC02 Series voltage protection relays are rail mounted devices. Make sure that the device is used only for intended purpose. The shielding must be grounded on the instrument side. During an installation, all of the cables that are connected to the device must be free of energy. The device must be protected against inadmissible humidity, vibrations, severe soiling and make sure that the operation temperature is not exceeded. All input and output lines that are not connected to the supply network must be laid out as shielded and twisted cables. These cables should not be close to the power cables or components. The installation and electrical connections must be carried on by a qualified staff and must be according to the relevant locally applicable regulations.



- 1) Mains supply cords shall meet the requirements of IEC60227 or IEC60245.
- 2) In accordance with the safety regulations, the power supply switch shall bring the identification of the relevant instrument and it should be easily accessible by the operator.

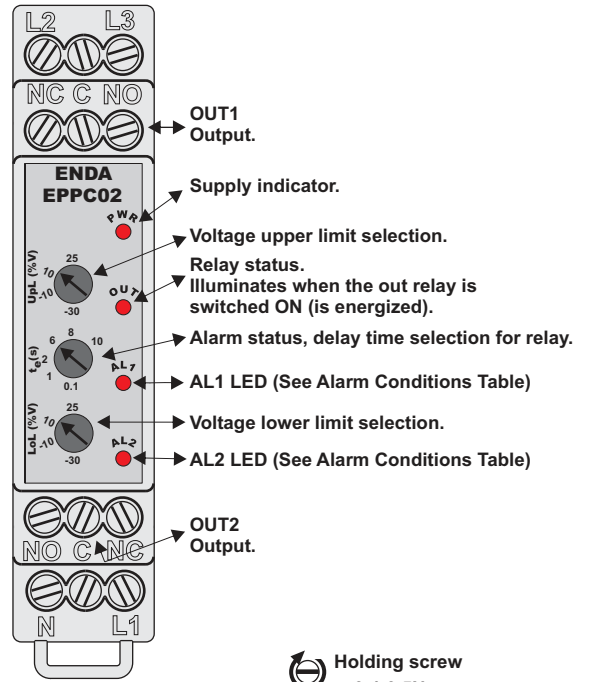

Holding screw
0.4-0.5Nm.

DIMENSIONS

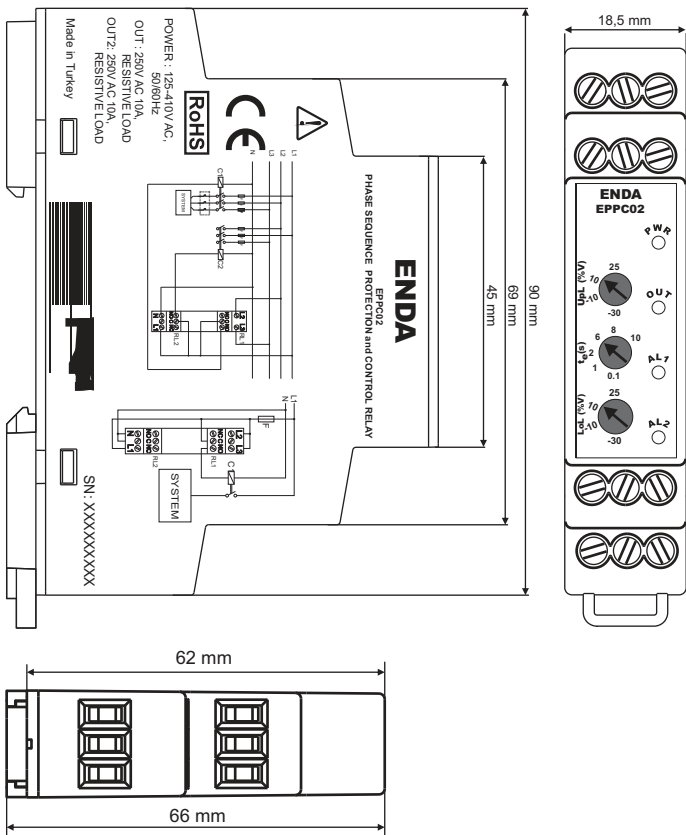

MONTAGE

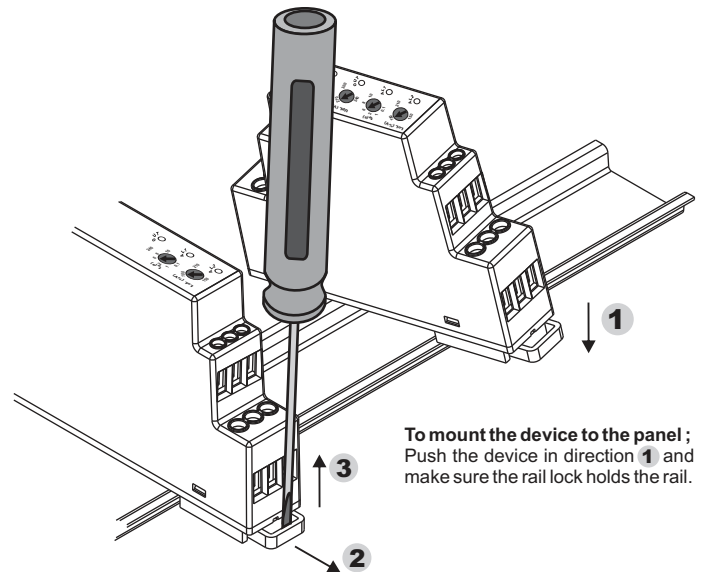

To mount the device to the panel ; Push the device in direction **1** and make sure the rail lock holds the rail.

To removing the device from rail ; Push the rail lock in direction **2** with a screwdriver and pull the device in direction **3**.