



Read this document carefully before using this device! The guarantee will be expired by damaging of the device if you don't attend to the directions in the user manual. Also we don't accept any compensations for personal injury, material damage or capital disadvantages.

ENDA EUP1222

RAIL MOUNTED NFC UNIVERSAL PID CONTROLLER

- ▶ DIN Rail Mounting,
- ▶ Selectable dual-set value,
- ▶ Selectable PT100, J, K, L, T, S, R sensor types,
- ▶ Selectable 0-20mA, 4-20mA, 0-10V, 2-10V, 0-25mV and 0-50mV input types,
- ▶ Programmable D1 and D2 digital contact input,
- ▶ Auto calculation for PID parameters (SELF TUNE),

⚠ Before starting the system for the first time, if the PID parameters of the system are known, they must be entered, otherwise the Self-Tune feature must be activated.

- ▶ Control outputs can be disabled (Applied for measurement use),
- ▶ Manual control for C/A2 or ANL/SSR outputs,
- ▶ Soft-Start feature,
- ▶ Communication via RS485 Modbus protocol,
- ▶ Selectable analogue, SSR or relay output control,
- ▶ Selectable 0-20mA, 4-20mA analogue output,
- ▶ C/A2 relay output can be set as secondary alarm or temperature control output,
- ▶ Heating/Cooling control type selection,
- ▶ Offset feature for input,
- ▶ In case of sensor failure, relay positions can be selected or periodic operation can be performed,
- ▶ Up to 16 steps profile controlling feature,
- ▶ Optional contact output triggering feature at profile steps,
- ▶ Timer or thermostat feature can be used during profile controlling,
- ▶ Heating error monitoring feature,
- ▶ Possibility to edit all parameters and view measurement/output values via NFC,
- ▶ CE Marked according to European Norms.



ORDER CODE : EUP1222



TECHNICAL SPECIFICATIONS

ELECTRICAL CHARACTERISTICS	
Supply	24 VDC ±20%.
Power Consumption	Max. 5VA.
Wiring	1.5mm ² screw-terminal connections.
Line Resistance	Max. 100Ω Ohm for thermocouple, max. 20Ω ohm for three-wire PT100.
Data Retention	FLASH Memory (minimum 20 years).
EMC	EN 61326-1: 2021
Safety Requirements	EN 61010-1: 2010 (Pollution degree 2, overvoltage category II)

ENVIRONMENTAL CONDITIONS

Ambient/Storage Temperature	0 ...+50°C/-25 ...+70°C (with no icing).
Max. Relative Humidity	%80, Relative humidity for temperatures up to 31°C, decreasing linearly to %50 at 40°C.
Protection Rating	According to EN 60529 IP20.
Height	Max. 2000m.



KEEP AWAY device from exposed to corrosive, volatile and flammable gases or liquids.

INPUTS

D1 Dry Contact Input	Programmable 1st. control key input.
D2 Dry Contact Input	Programmable 2nd. control key input.

OUTPUTS

C/A2 Output	Relay : 250V AC, 5A (for resistive load), NO (Control or Alarm2 Output selection)
A1 Output	Relay : 250V AC, 5A (for resistive load), NO Control.
ANL/SSR Outputs	Selectable 0-20mA and 4-20mA analog output; SSR 15V 20mA Maximum load resistance is 500Ω Ohm on mA output and SSR mode
Life Expectancy for Relay	Without load 10.000.000 switching; 250V AC, 5A (resistive load) 300.000 switching.

CONTROL

Control Type	Single set-point and alarm control.
Control Algorithm	On-Off / P, PI, PD, PID (selectable).
A/D Converter	14 bits.
Sampling Time	100ms (Minimum)
Proportional Band	Adjustable between %0.0 and %100.0. If Pb=%0.0 On-Off control is selected.
Integral Time	Adjustable between 0.0 and 100.0 minutes.
Derivative Time	Adjustable between 0.00 and 25.00 minutes.
Control Period	Adjustable between 1 and 125 seconds.
Hysteresis	Adjustable between 1 and 50°C/F.
Output Power	The ratio of power at the setpoint value can be set between 0% and 100%.

HOUSING

Housing Type	Rail - mounted box according to DIN 43 700.
Dimensions	W22.5xH96xD86mm
Weight	Approx. 158g (after packing)
Enclosure Material	Self extinguishing plastics used.

 **DO NOT clean the device with solvent (thinner, gasoline, acid etc.) and / or abrasive cleaning agents.**

ANALOG INPUTS

Input Type		Scale Range		Accuracy
PT100 Resistance Thermometer	EN 60751	-199.9 ...600.0°C	-199.9 ...999.0°F	± 0,2% (for full scale) ± 1 digit
PT100 Resistance Thermometer	EN 60751	-200 ...600°C	-328 ...1112°F	± 0,2% (for full scale) ± 1 digit
J (Fe-CuNi) Thermocouple	EN 60584	-30.0 ...600.0°C	-22.0 ...999.0°F	± 0,5% (for full scale) ± 1 digit
J (Fe-CuNi) Thermocouple	EN 60584	-30 ...600°C	-22 ...1112°F	± 0,5% (for full scale) ± 1 digit
K (NiCr-Ni) Thermocouple	EN 60584	-30.0 ...999.9°C	-22.0 ...999.9°F	± 0,5% (for full scale) ± 1 digit
K (NiCr-Ni) Thermocouple	EN 60584	-30 ...1300°C	-22 ...2372°F	± 0,5% (for full scale) ± 1 digit
L (Fe-CuNi) Thermocouple	DIN 43710	-30.0 ...600.0°C	-22.0 ...999.9°F	± 0,5% (for full scale) ± 1 digit
L (Fe-CuNi) Thermocouple	DIN 43710	-30 ...600°C	-22 ...1112°F	± 0,5% (for full scale) ± 1 digit
T (Cu-CuNi) Thermocouple	EN 60584	-30.0 ...400.0°C	-22.0 ...752.0°F	± 0,5% (for full scale) ± 1 digit
T (Cu-CuNi) Thermocouple	EN 60584	-30 ...400°C	-22 ...752°F	± 0,5% (for full scale) ± 1 digit
S (Pt10Rh-Pt) Thermocouple	EN 60584	-40 ...1700°C	-40 ...3092°F	± 0,5% (for full scale) ± 1 digit
R (Pt10Rh-Pt) Thermocouple	EN 60584	-40 ...1700°C	-40 ...3092°F	± 0,5% (for full scale) ± 1 digit
0-20mA input		-10000...+10000 (max. scale range 10000)		± 0,2% (for full scale) ± 1 digit
4-20mA input		-10000...+10000 (max. scale range 10000)		± 0,2% (for full scale) ± 1 digit
0-10V input		-10000...+10000 (max. scale range 10000)		± 0,2% (for full scale) ± 1 digit
2-10V input		-10000...+10000 (max. scale range 10000)		± 0,2% (for full scale) ± 1 digit
0-25mV input		-10000...+10000 (max. scale range 10000)		± 0,2% (for full scale) ± 1 digit
0-50mV input		-10000...+10000 (max. scale range 10000)		± 0,2% (for full scale) ± 1 digit

Connection Diagram



ENDA EUP1222 devices are intended for rail mounted installations. Make sure that the device is used only for intended purpose. The shielding must be grounded on the instrument side. During an installation, all of the cables that are connected to the device must be free of electrical power. The device must be protected against inadmissible humidity, vibrations, severe soiling. Make sure that the operation temperature is not exceeded. All input and output lines that are not connected to the supply network must be laid out as shielded and twisted cables. These cables should not be close to the power cables or components. The installation and electrical connections must be carried out by a qualified staff and must be according to the relevant locally applicable regulations.

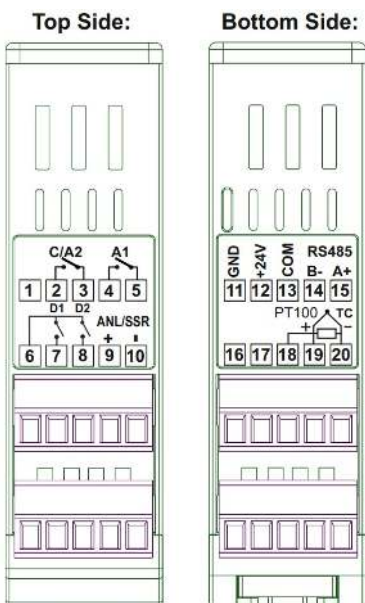

The logic output of the instrument is not electrically insulated from the internal circuits. Therefore, when using a grounded thermocouple, do not connect the logic output terminals to the earth.

Mains Connections:

NOTE :

SUPPLY :

19,2-28,8V DC
1A



Ground protection input must be connected to the earth line.



1- Mains supply cords shall meet the requirements of IEC60227 or IEC60245. 2- In accordance with the safety regulations, the power supply switch shall bring the identification of the relevant instrument and it should be easily accessible by the operator.

Sensor Inputs

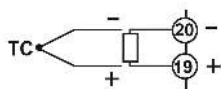

• **J-K-L-T-S-R Type Thermocouples:**

Use the correct compensation cables for thermocouples. Do not use jointed cables. Make sure to connect to the right place and right polarities at the input terminals as shown in the figure.

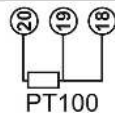

• **Resistance (PT100) Thermocouples:**

Make short circuits 18 and 19 terminal lines for two-wire PT100 sensors. Do not use jointed cables. Long cable causes incorrect temperature measurement.

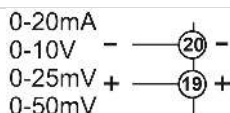

• **0-20mA, 4-20mA, 0-10V, 2-10V, 0-25mV and 0-50mV Inputs:**

Make sure to connect to the right place and right polarities at the input terminals as shown in the figure. Do not use jointed cables. Long cable causes incorrect measurement results.

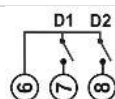

• **D1 and D2 Dry Contact Inputs:**

Dry contacts must be used with mechanical keys.



Holding screw
0,4-0,5Nm



Equipment is protected throughout by
DOUBLE INSULATION

ERROR INDICATOR LED

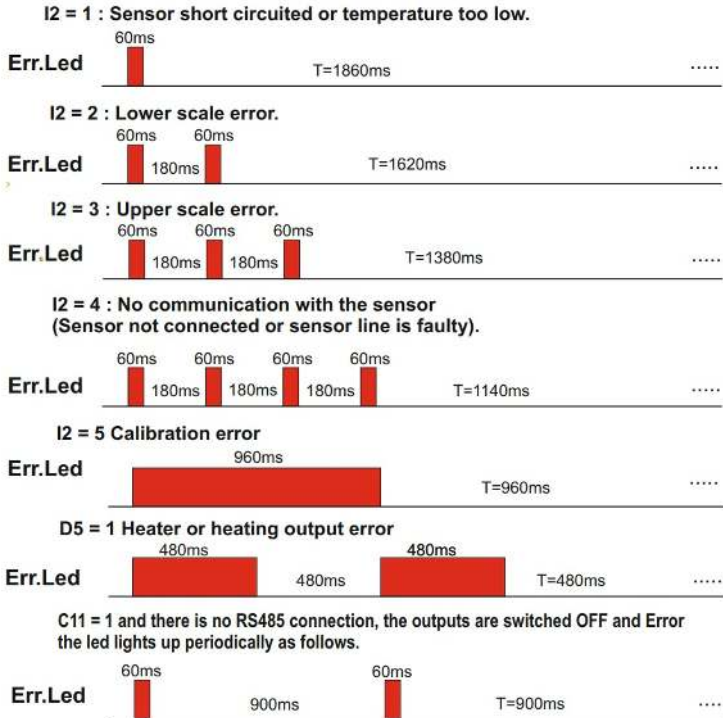

Note: The Err LED flashes periodically when an error condition occurs. For example, in the case of an upper-scale error, the Err LED on the third graph will flash three times every 180 ms for a duration of 60 ms, and this cycle repeats after 1380 ms. When the error is resolved, the LED turns off.

Dimensions

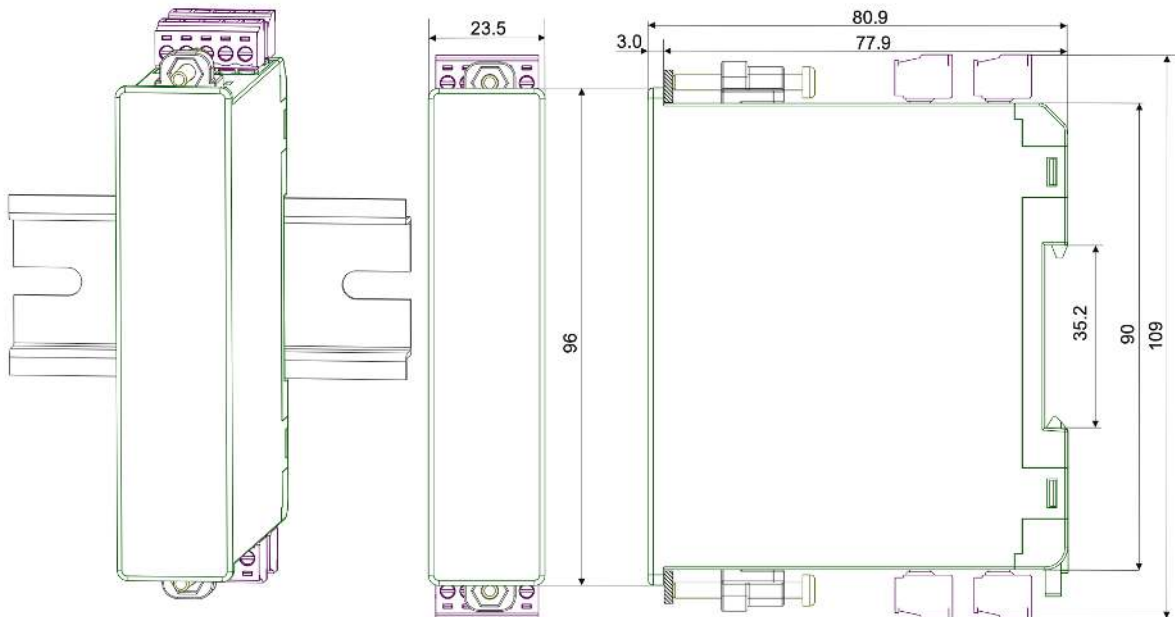

NOTE: Measurement unit is millimeter.

Alarm1 And Alarm2 Output Types

Diagrams are based on Alarm1 graphics.

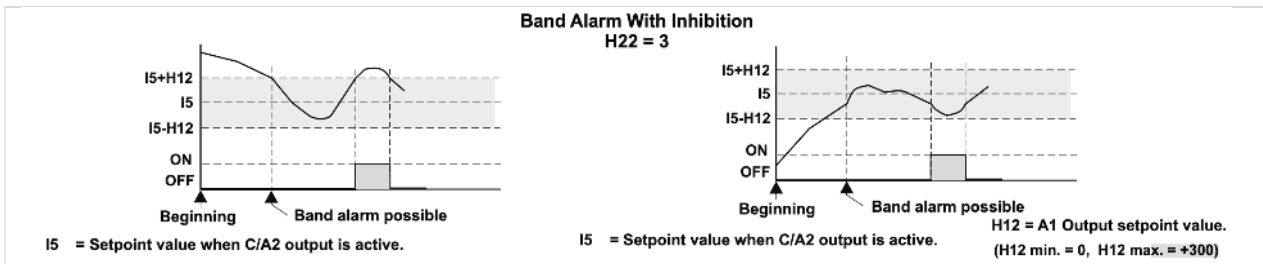
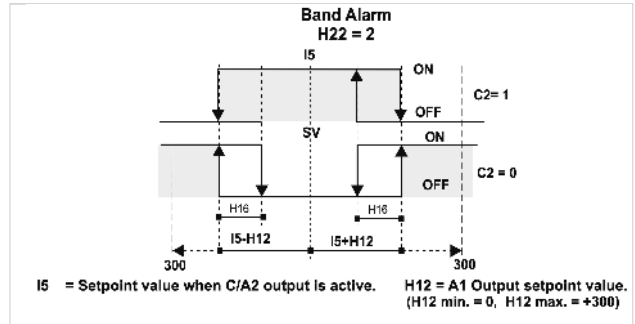
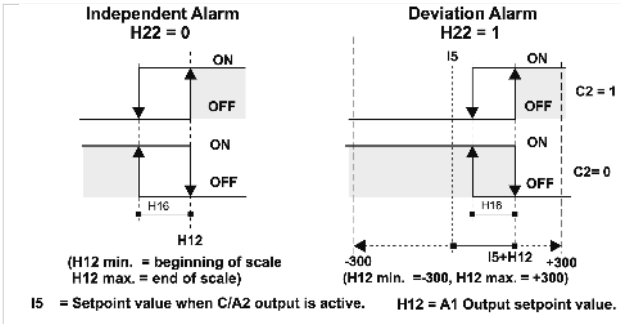

Timer / Thermostat Output Examples

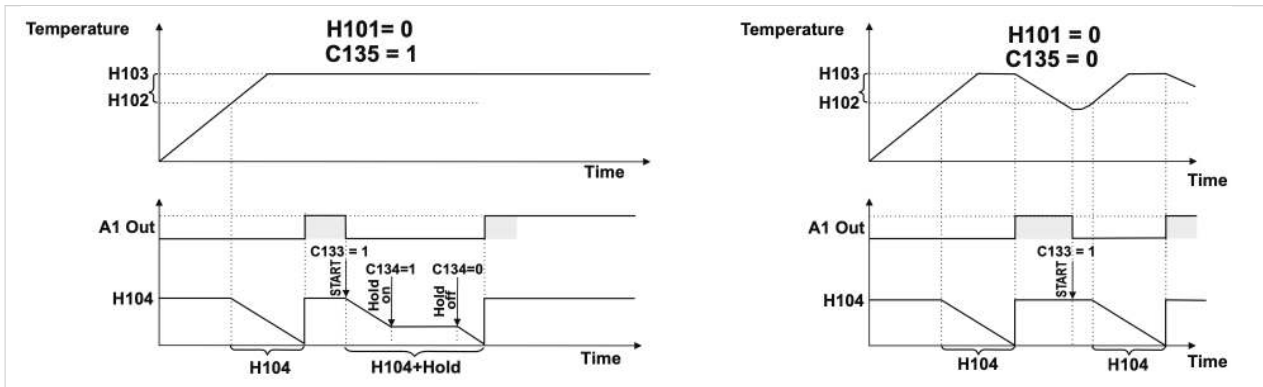

Profile Control Output Examples

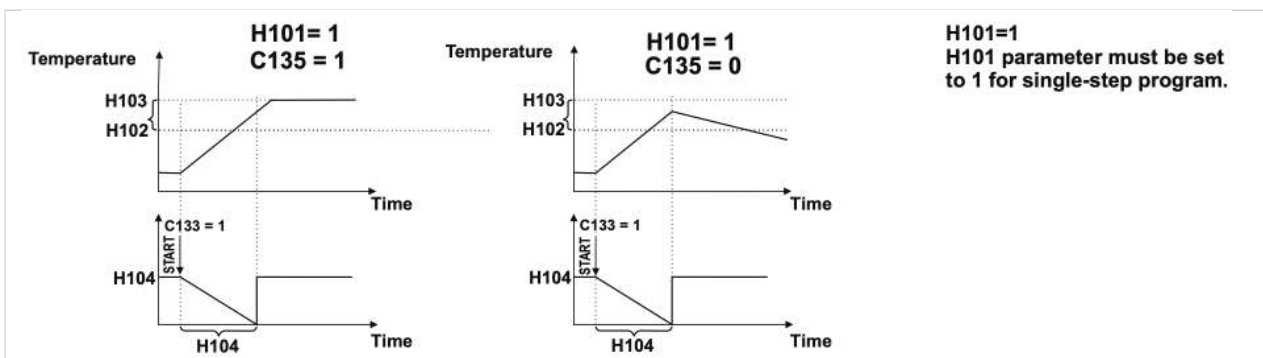

Multi-Step Profile Control Output Example

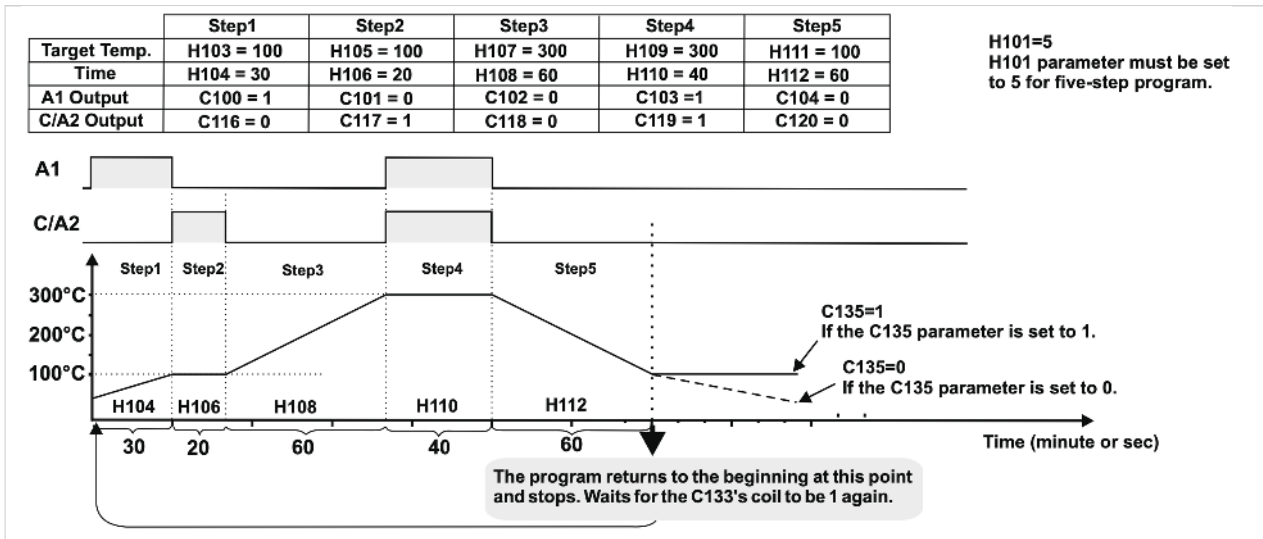

EUP1222 Universal PID Controller Modbus Map

Holding Registers

Param	Register Addresses		Data Type	Description	Permission	Default
	Decimal	Hex				
H0	0	0x0000	word	Control output temperature setpoint value	Readable Writable	400
H1	1	0x0001	word	Control output 2nd temperature setpoint value	Readable Writable	500
H2	2	0x0002	word	Control output minimum setpoint value	Readable Writable	-30
H3	3	0x0003	word	Control output maximum setpoint value	Readable Writable	600
H4	4	0x0004	word	Control output proportional band setpoint value (Adjustable between %0.0 and %100.0)	Readable Writable	4.0
H5	5	0x0005	word	Control output hysteresis value (Adjustable between 1 and 50 °C or °F)	Readable Writable	2
H6	6	0x0006	word	Control output integral time (Adjustable between 0.0 and 100.0 minute)	Readable Writable	4.0
H7	7	0x0007	word	Control output derivative time (Adjustable between 0.00 and 25.00 minute)	Readable Writable	1.00

Param	Register Addresses		Data Type	Description	Permission	Default
	Decimal	Hex				
H8	8	0x0008	word	Control output time period set-point value (Adjustable between 1 and 125 second)	Readable Writable	1
H9	9	0x0009	word	Control output set value power ratio (Adjustable between %0 and %100)	Readable Writable	0
H10	10	0x000A	word	Control output set value power ratio in case of sensor failure (Adjustable between %0 and %100)	Readable Writable	0
H11	11	0x000B	word	Soft start time for control output (Adjustable between 0 - 250 min)	Readable Writable	0
H12	12	0x000C	word	Alarm1 output temperature setpoint value	Readable Writable	500
H13	13	0x000D	word	Alarm1 output minimum setpoint value limit	Readable Writable	-30
H14	14	0x000E	word	Alarm1 output maximum setpoint value limit	Readable Writable	600
H15	15	0x000F	word	Alarm1 output proportional band set value (Adjustable between %0.0 and %100.0)	Readable Writable	0.0
H16	16	0x0010	word	Alarm1 output hysteresis value (Adjustable between 1 and 50 °C or °F)	Readable Writable	2
H17	17	0x0011	word	Alarm1 output, integral time (Adjustable between 0.0 and 100.0 minute)	Readable Writable	0.0
H18	18	0x0012	word	Alarm1 output derivative time (Adjustable between 0.00 and 25.00 minute)	Readable Writable	0.00
H19	19	0x0013	word	Period time value of the Alarm1 output (Adjustable between 1 - 250 sec.)	Readable Writable	1
H20	20	0x0014	word	Alarm1 output set value power ratio (Adjustable between %0 and %100)	Readable Writable	0
H21	21	0x0015	word	Alarm1 output set value power ratio in case of sensor failure (Adjustable between %0 and %100)	Readable Writable	0

Param	Register Addresses		Data Type	Description	Permission	Default
	Decimal	Hex				
H22	22	0x0016	word	Alarm1 output type selection 0: Independent Alarm 1: Deviation Alarm 2: Band Alarm 3: Active Alarm After in Band Time 4: Alarm1 Output Independent Cooling Control 5: Alarm1 Output Relative Cooling Control	Readable Writable	0
H23	23	0x0017	word	Alarm2 output temperature setpoint value	Readable Writable	500
H24	24	0x0018	word	Alarm2 output minimum setpoint value limit	Readable Writable	-30
H25	25	0x0019	word	Alarm2 output maximum setpoint value limit	Readable Writable	600
H26	26	0x001A	word	Alarm2 output hysteresis value (Adjustable between 1 and 50 °C or °F)	Readable Writable	2
H27	27	0x001B	word	Alarm2 output type selection 0: Independent Alarm 1: Deviation Alarm 2: Band Alarm 3: Active Alarm After in Band Time	Readable Writable	0
H28	28	0x001C	word	Input type selection 0: PT100 decimal 1: PT100 2: J decimal 3: J 4: K decimal 5: K 6: L decimal 7: L 8: T decimal 9: T 10: S 11: R 12: 0-20mA 13: 4-20mA 14: 0-10V 15: 2-10V 16: 0-25mV 17: 0-50mV	Readable Writable	3
H29	29	0x001D	word	Control output heating control time (If 0, output heating error control is not performed. Values up to 1000 seconds can be entered. If the temperature change is not provided at the end of the time, an error message is generated.)	Readable Writable	60

Param	Register Addresses		Data Type	Description	Permission	Default
	Decimal	Hex				
H30	30	0x001E	word	Modbus baudrate 0: 2400 bps 1: 4800 bps 2: 9600 bps, 3: 19200 bps, 4: 38400 bps, 5: 57200 bps, 6: 115200 bps	Readable Writable	2
H31	31	0x001F	word	Digital filter coefficient (Adjustable between 1 - 200. If digital filter coefficient is 1, digital filter disabled).	Readable Writable	20
H32	32	0x0020	word	Control output selection value 0: C/A2 (Relay) Output 1: SSR Output 2: SSR/ANL 0-20mA Output 3: SSR/ANL 4-20mA Output	Readable Writable	0
H33	33	0x0021	word	Minimum percentage of analog output value	Readable Writable	0
H34	34	0x0022	word	Maximum percentage of analog output value	Readable Writable	100
H35	35	0x0023	word	Offset value (Adjustable between -100 and 100)	Readable Writable	0
H36	36	0x0024	word	Function control parameter. (If 23040d (5A00h) value is entered, self tune is stopped.) (If 23041d (5A01h) value is entered, self tune is started.) (If 23042d (5A02h) value is entered, H1...H41 and C0...C10 parameters returns to the factory defaults.) (If 23043d (5A03h) value is entered, H100...H137 and C100...C138 parameters returns to the factory defaults.)(This parameter should not change from EndaLink app!!)	Readable Writable	0
H39	39	0x0027	word	Manual control output percentage (Adjustable between %0 and %100)	Readable Writable	50

Param	Register Addresses		Data Type	Description	Permission	Default
	Decimal	Hex				
H40	40	0x0028	word	D1 digital contact input control parameter 0: D1 input is not used. D1 input is OFF = H0 parameter, D1 input is ON, H2 parameter is used as control set value. 2: If D1 input is OFF = auto control, If ON, manual control. 3: If D1 input is OFF = thermostat, If ON, indicator mode is entered. 4: If D1 input is OFF = profile start, If ON, profile stop. 5: If D1 input is OFF = hold off, If ON, hold on.	Readable Writable	0
H41	41	0x0029	word	D2 digital contact input control parameter 0: D2 input is not used. 1: If D2 input is OFF = H0 parameter, If ON = D2 input is ON, H2 parameter is used as control set value. 2: If D2 input is OFF = auto control. If ON, manual control. 3: If D2 input is OFF = thermostat. If ON, indicator mode is entered. 4: If D2 input is OFF = profile start. If ON, profile stop. 5: If D2 input is OFF = hold off, If ON, hold on.	Readable Writable	0
H42	42	0x002A	word	Retransmission output control parameter. ATTENTION!! For this parameter to be set, H32 = 0. 0: Retransmission out is off 1: Analog output is 0-20mA retransmission out 2: Analog output is 4-20mA retransmission out	Readable Writable	0
H43	43	0x002B	word	Retransmission output lower scale value	Readable Writable	-30
H44	44	0x002C	word	Retransmission output upper scale value	Readable Writable	600
H45	45	0x002D	word	Decimal point settings for mA, V inputs 0: No decimal point 1: One digit after the dot (0.0) 2: Two digit after the dot (0.00) 3: Three digit after the dot (0.000)	Readable Writable	0
H46	46	0x002E	word	User lower scale limit for 0-20mA, 4-20mA, 0-10V and 2-10V input selections	Readable Writable	-1999

Param	Register Addresses		Data Type	Description	Permission	Default
	Decimal	Hex				
H47	47	0x002F	word	User upper scale limit for 0-20mA, 4-20mA, 0-10V and 2-10V input selections	Readable Writable	2000
H48	48	0x0030	word	Modbus slave address	Readable Writable	1
H52	52	0x0034	word	Time to turn off the outputs after the RS485 signal is cut off (Adjustable between 2 and 9999 seconds. ATTENTION !! C11 = 1 for this timing to work.)	Readable Writable	2
H100	100	0x0064	word	Profile time base set value. (0 = 9999s, 1 = 9999m)	Readable Writable	0
H101	101	0x0065	word	Maximum number of steps (Adjustable between 0 and 16. If it is 0, in timer/thermostat mode)	Readable Writable	8
H102	102	0x0066	word	Step end temperature difference. (It can be set between 0 and H3 parameter. If the step time is reached before the target temperature is reached when the profile is checked, then the difference between the target temperature and the measured temperature is expected to be less than or equal to this parameter value and then proceed to the next step. If the difference is smaller than or equal to this parameter, the timer is switched on)	Readable Writable	5
H103	103	0x0067	word	1st. Step, set value of target temperature (Parameter set between H2 and H3)	Readable Writable	200
H104	104	0x0068	word	1st. Step time value (Can be set between 0 and 9999s or 9999m (varies according to H100 parameter))	Readable Writable	60
H105	105	0x0069	word	2nd. Step set value of target temperature (Parameter set between H2 and H3)	Readable Writable	201
H106	106	0x006A	word	2nd. Step time value (Can be set between 0 and 9999s or 9999m (varies according to H100 parameter))	Readable Writable	61
H107	107	0x006B	word	3rd. Step set value of target temperature (Parameter set between H2 and H3)	Readable Writable	202
H108	108	0x006C	word	3rd. Step time value (Can be set between 0 and 9999s or 9999m (varies according to H100 parameter))	Readable Writable	62

Param	Register Addresses		Data Type	Description	Permission	Default
	Decimal	Hex				
H109	109	0x006D	word	4th. Step set value of target temperature (Parameter set between H2 and H3)	Readable Writable	203
H110	110	0x006E	word	4th. Step time value (Can be set between 0 and 9999s or 9999m (varies according to H100 parameter))	Readable Writable	63
H111	111	0x006F	word	5th. Step set value of target temperature (Parameter set between H2 and H3)	Readable Writable	204
H112	112	0x0070	word	5th. Step time value (Can be set between 0 and 9999s or 9999m (varies according to H100 parameter))	Readable Writable	64
H113	113	0x0071	word	6th. Step set value of target temperature (Parameter set between H2 and H3)	Readable Writable	205
H114	114	0x0072	word	6th. Step time value (Can be set between 0 and 9999s or 9999m (varies according to H100 parameter))	Readable Writable	65
H115	115	0x0073	word	7th. Step set value of target temperature (Parameter set between H2 and H3)	Readable Writable	206
H116	116	0x0074	word	7th. Step time value (Can be set between 0 and 9999s or 9999m (varies according to H100 parameter))	Readable Writable	66
H117	117	0x0075	word	8th. Step set value of target temperature (Parameter set between H2 and H3)	Readable Writable	207
H118	118	0x0076	word	8th. Step, time value (Can be set between 0 and 9999s or 9999m (varies according to H100 parameter))	Readable Writable	67
H119	119	0x0077	word	9th. Step set value of target temperature (Parameter set between H2 and H3)	Readable Writable	208
H120	120	0x0078	word	9th. Step time value (Can be set between 0 and 9999s or 9999m (varies according to H100 parameter))	Readable Writable	68
H121	121	0x0079	word	10th. Step set value of target temperature (Parameter set between H2 and H3)	Readable Writable	209

Param	Register Addresses		Data Type	Description	Permission	Default
	Decimal	Hex				
H122	122	0x007A	word	10th. Step time value (Can be set between 0 and 9999s or 9999m (varies according to H100 parameter))	Readable Writable	69
H123	123	0x007B	word	11th. Step set value of target temperature (Parameter set between H2 and H3)	Readable Writable	210
H124	124	0x007C	word	11th. Step time value (Can be set between 0 and 9999s or 9999m (varies according to H100 parameter))	Readable Writable	70
H125	125	0x007D	word	12th. Step set value of target temperature (Parameter set between H2 and H3)	Readable Writable	211
H126	126	0x007E	word	12th. Step time value (Can be set between 0 and 9999s or 9999m (varies according to H100 parameter))	Readable Writable	71
H127	127	0x007F	word	13th. Step set value of target temperature (Parameter set between H2 and H3)	Readable Writable	212
H128	128	0x0080	word	13th. Step time value (Can be set between 0 and 9999s or 9999m (varies according to H100 parameter))	Readable Writable	72
H129	129	0x0081	word	14th. Step set value of target temperature (Parameter set between H2 and H3)	Readable Writable	213
H130	130	0x0082	word	14th. Step time value (Can be set between 0 and 9999s or 9999m (varies according to H100 parameter))	Readable Writable	73
H131	131	0x0083	word	15th. Step set value of target temperature (Parameter set between H2 and H3)	Readable Writable	214
H132	132	0x0084	word	15th. Step time value (Can be set between 0 and 9999s or 9999m (varies according to H100 parameter))	Readable Writable	74
H133	133	0x0085	word	16th. Step set value of target temperature (Parameter set between H2 and H3)	Readable Writable	215
H134	134	0x0086	word	16th. Step time value (Can be set between 0 and 9999s or 9999m (varies according to H100 parameter))	Readable Writable	75

Param	Register Addresses		Data Type	Description	Permission	Default
	Decimal	Hex				
H135	135	0x0087	word	Thermostat mode step time (Can be set between 0 and 9999s or 9999m (if C132 = 0 step time value))	Readable Writable	30

Coils

Param	Register Addresses		Data Type	Description	Permission	Default
	Decimal	Hex				
C0	0	0x0000	bit	Alarm2 Status 0: Alarm on under set value 1: Alarm on above set value	Readable Writable	1
C1	1	0x0001	bit	Alarm2 output position in case of probe failure 0: Off 1: On	Readable Writable	1
C2	2	0x0002	bit	Alarm1 Status 0: Alarm on under set value 1: Alarm on above set value	Readable Writable	1
C3	3	0x0003	bit	Alarm1 output position in case of probe failure 0: Off 1: On	Readable Writable	1
C4	4	0x0004	bit	Control output configuration 0: Heating Control 1: Cooling Control	Readable Writable	0
C5	5	0x0005	bit	Temperature unit 0: °C 1: °F	Readable Writable	0
C6	6	0x0006	bit	Control outputs status 0: Display Mode (Outputs off) 1: Control Outputs are Active	Readable Writable	1
C7	7	0x0007	bit	Controlling according to 2nd temperature setpoint 0: Temperature control according to H0 parameter 1: Temperature control according to H1 parameter	Readable Writable	0

Param	Register Addresses		Data Type	Description	Permission	Default
	Decimal	Hex				
C8	8	0x0008	bit	Manual control bit 0: Automatic control 1: C/A2 output or ANL/SSR output is given according to the output percentage in the H39 parameter.	Readable Writable	0
C9	9	0x0009	bit	Control format in case of probe failure 0: According to H10 percentage value proportional control. 1: Error found before the set-point control is done with the value of the proportional control.	Readable Writable	0
C10	10	0x000A	bit	Self tune control selection 0: Self tune is stopped. 1: Self tune is started.	Readable Writable	0
C11	11	0x000B	bit	RS485 disconnection error checking 0: RS485 connection error check is off. 1: RS485 connection error check is active	Readable Writable	0
C100	100	0x0064	bit	Step 1 in profile steps: A1 alarm output coil. 0: A1 output is OFF at 1. step. 1: A1 output is ON at 1. step.	Readable Writable	0
C101	101	0x0065	bit	Step 2 in profile steps: A1 alarm output coil. 0: A1 output is OFF at 2. step. 1: A1 output is ON at 2. step.	Readable Writable	0
C102	102	0x0066	bit	Step 3 in profile steps: A1 alarm output coil. 0: A1 output is OFF at 3. step. 1: A1 output is ON at 3. step.	Readable Writable	0
C103	103	0x0067	bit	Step 4 in profile steps: A1 alarm output coil. 0: A1 output is OFF at 4. step. 1: A1 output is ON at 4. step.	Readable Writable	0
C104	104	0x0068	bit	Step 5 in profile steps: A1 alarm output coil. 0: A1 output is OFF at 5. step. 1: A1 output is ON at 5. step.	Readable Writable	0

Param	Register Addresses		Data Type	Description	Permission	Default
	Decimal	Hex				
C105	105	0x0069	bit	Step 6 in profile steps: A1 alarm output coil. 0: A1 output is OFF at 6. step. 1: A1 output is ON at 6. step.	Readable Writable	0
C106	106	0x006A	bit	Step 7 in profile steps: A1 alarm output coil. 0: A1 output is OFF at 7. step. 1: A1 output is ON at 7. step.	Readable Writable	0
C107	107	0x006B	bit	Step 8 in profile steps: A1 alarm output coil. 0: A1 output is OFF at 8. step. 1: A1 output is ON at 8. step.	Readable Writable	0
C108	108	0x006C	bit	Step 9 in profile steps: A1 alarm output coil. 0: A1 output is OFF at 9. step. 1: A1 output is ON at 9. step.	Readable Writable	0
C109	109	0x006D	bit	Step 10 in profile steps: A1 alarm output coil. 0: A1 output is OFF at 10. step. 1: A1 output is ON at 10. step.	Readable Writable	0
C110	110	0x006E	bit	Step 11 in profile steps: A1 alarm output coil. 0: A1 output is OFF at 11. step. 1: A1 output is ON at 11. step.	Readable Writable	0
C111	111	0x006F	bit	Step 12 in profile steps: A1 alarm output coil. 0: A1 output is OFF at 12. step. 1: A1 output is ON at 12. step.	Readable Writable	0
C112	112	0x0070	bit	Step 13 in profile steps: A1 alarm output coil. 0: A1 output is OFF at 13. step. 1: A1 output is ON at 13. step.	Readable Writable	0
C113	113	0x0071	bit	Step 14 in profile steps: A1 alarm output coil. 0: A1 output is OFF at 14. step. 1: A1 output is ON at 14. step.	Readable Writable	0
C114	114	0x0072	bit	Step 15 in profile steps: A1 alarm output coil. 0: A1 output is OFF at 15. step. 1: A1 output is ON at 15. step.	Readable Writable	0

Param	Register Addresses		Data Type	Description	Permission	Default
	Decimal	Hex				
C115	115	0x0073	bit	Step 16 in profile steps: A1 alarm output coil. 0: A1 output is OFF at 16. step. 1: A1 output is ON at 16. step.	Readable Writable	0
C116	116	0x0074	bit	Step 1 in profile steps: C/A2 alarm output coil. 0: C/A2 output is OFF at 1. step. 1: C/A2 output is ON at 1. step.	Readable Writable	0
C117	117	0x0075	bit	Step 2 in profile steps: C/A2 alarm output coil. 0: C/A2 output is OFF at 2. step. 1: C/A2 output is ON at 2. step.	Readable Writable	0
C118	118	0x0076	bit	Step 3 in profile steps: C/A2 alarm output coil. 0: C/A2 output is OFF at 3. step. 1: C/A2 output is ON at 3. step.	Readable Writable	0
C119	119	0x0077	bit	Step 4 in profile steps: C/A2 alarm output coil. 0: C/A2 output is OFF at 4. step. 1: C/A2 output is ON at 4. step.	Readable Writable	0
C120	120	0x0078	bit	Step 5 in profile steps: C/A2 alarm output coil. 0: C/A2 output is OFF at 5. step. 1: C/A2 output is ON at 5. step.	Readable Writable	0
C121	121	0x0079	bit	Step 6 in profile steps: C/A2 alarm output coil. 0: C/A2 output is OFF at 6. step. 1: C/A2 output is ON at 6. step.	Readable Writable	0
C122	122	0x007A	bit	Step 7 in profile steps: C/A2 alarm output coil. 0: C/A2 output is OFF at 7. step. 1: C/A2 output is ON at 7. step.	Readable Writable	0
C123	123	0x007B	bit	Step 8 in profile steps: C/A2 alarm output coil. 0: C/A2 output is OFF at 8. step. 1: C/A2 output is ON at 8. step.	Readable Writable	0

Param	Register Addresses		Data Type	Description	Permission	Default
	Decimal	Hex				
C124	124	0x007C	bit	Step 9 in profile steps: C/A2 alarm output coil. 0: C/A2 output is OFF at 9. step. 1: C/A2 output is ON at 9. step.	Readable Writable	0
C125	125	0x007D	bit	Step 10 in profile steps: C/A2 alarm output coil. 0: C/A2 output is OFF at 10. step. 1: C/A2 output is ON at 10. step.	Readable Writable	0
C126	126	0x007E	bit	Step 11 in profile steps: C/A2 alarm output coil. 0: C/A2 output is OFF at 11. step. 1: C/A2 output is ON at 11. step.	Readable Writable	0
C127	127	0x007F	bit	Step 12 in profile steps: C/A2 alarm output coil. 0: C/A2 output is OFF at 12. step. 1: C/A2 output is ON at 12. step.	Readable Writable	0
C128	128	0x0080	bit	Step 13 in profile steps: C/A2 alarm output coil. 0: C/A2 output is OFF at 13. step. 1: C/A2 output is ON at 13. step.	Readable Writable	0
C129	129	0x0081	bit	Step 14 in profile steps: C/A2 alarm output coil. 0: C/A2 output is OFF at 14. step. 1: C/A2 output is ON at 14. step.	Readable Writable	0
C130	130	0x0082	bit	Step 15 in profile steps: C/A2 alarm output coil. 0: C/A2 output is OFF at 15. step. 1: C/A2 output is ON at 15. step.	Readable Writable	0
C131	131	0x0083	bit	Step 16 in profile steps: C/A2 alarm output coil. 0: C/A2 output is OFF at 16. step. 1: C/A2 output is ON at 16. step.	Readable Writable	0

Param	Register Addresses		Data Type	Description	Permission	Default
	Decimal	Hex				
C132	132	0x0084	bit	Controlled according to the set value or profile control selection. 0: Thermostat mode 1: Profile control mode	Readable Writable	0
C133	133	0x0085	bit	0: Profile mode is stopped and returned to first step. 1: Profile mode is started.	Readable Writable	0
C134	134	0x0086	bit	0: Profile mode is started, process runs. 1: Profile operation is suspended at the recent point. (Hold mode)	Readable Writable	0
C135	135	0x0087	bit	0: When profile finished, control process stops. (Control outputs are OFF). 1: When profile finished, control process continues according to last set value.	Readable Writable	0
C136	136	0x0088	bit	0: When power loss, profile stops and returned to first step. 1: When power up and if temperature setpoint in the current step, Profile continues. If the temperature setpoint is not in the current step, returned to first step.	Readable Writable	0
C137	137	0x0089	bit	0: A1 output is controlled by according to H22 parameter. 1: If C132 = 1, A1 output is controlled by according to H135 parameter for every steps.	Readable Writable	0
C138	138	0x008A	bit	0: A2 output is controlled by according to H27 parameter. 1: If C132 = 1, A2 output is controlled by according to H136 parameter for every steps.	Readable Writable	0

Discrete Registers

Param	Register Addresses		Data Type	Description	Permission	Default
	Decimal	Hex				
D0	0	0x0000	bit	C/A2 Control output status (0 = OFF, 1 = ON)	Readable	0
D1	1	0x0001	bit	A1 output status (0 = OFF, 1 = ON)	Readable	0
D2	2	0x0002	bit	SSR output status (0 = OFF, 1 = ON)	Readable	0
D3	3	0x0003	bit	D1 digital input status (0 = OFF, 1 = ON)	Readable	0
D4	4	0x0004	bit	D2 digital input status (0 = OFF, 1 = ON)	Readable	0
D5	5	0x0005	bit	Control output heating fault status (0 = No error, 1 = Heating not possible)	Readable	0
D100	100	0x0064	bit	If D100 = 1, Profile is in constant temperature step	Readable	0
D101	101	0x0065	bit	If D101 = 1, Profile is in heating step	Readable	0
D102	102	0x0066	bit	If D102 = 1, Profile is in cooling step	Readable	0
D103	103	0x0067	bit	If D103 = 1, Profile ended	Readable	0
D104	104	0x0068	bit	If D104 = 1, Step timer is 0.	Readable	0
D105	105	0x0069	bit	If D105 = 1, Step timer is running.	Readable	0

Input Registers

Param	Register Addresses		Data Type	Description	Permission	Default
	Decimal	Hex				
I0	0	0x0000	word	Measured temperature	Readable	0
I1	1	0x0001	word	Percentage of analog output(The value read from Modbus is the actual value multiplied by 100. For example: A value of 10000 read from Modbus corresponds to 100%, and the display format in EndaLink is 100.00%)	Readable	0.00
I2	2	0x0002	word	Measurement error codes (0 = No error, 1 = Sensor break error, 2 = Lower scale error, 3 = Upper scale error, 4 = Sensor broken, 5 = Calibration error)	Readable	0
I3	3	0x0003	word	Self tune status codes 0 = No error, 1 = Start temperature is higher than 60% of set value, 2 = Pid parameters are calculated, 3 = Power set parameter is calculated	Readable	0
I4	4	0x0004	word	Active temperature set value	Readable	0
I5	5	0x0005	word	Current (active) decimal point value (0 = No decimal point, 1 = 0.0, 2 = 0.00, 3 = 0.000)	Readable	0
I100	100	0x0064	word	The number of the active step	Readable	0
I101	101	0x0065	word	Remaining time display of active step	Readable	0
I102	102	0x0066	word	Target temperature value of active step	Readable	0

Modbus Error Messages

Modbus protocol has two types error, communication error and operating error. Reason of the communication error is data corruption in transmission. Parity and CRC control should be done to prevent communication error. Receiver side checks parity and CRC of the data. If they are wrong, the message will be ignored. If format of the data is true but function doesn't perform for any reason, operating error occurs. EUP1222 realizes error and sends error message. Most significant bit of function is changed '1' to indicate error in error message by EUP1222. Error code is sent in data section. EUP1222 realizes error type via this message.

MODBUS ERROR CODES

Error Code	Name	Meaning
{01}	Illegal Function	The function code received in the query is not an allowable action for the EUP1222. If a Poll Program Complete command was issued, this code indicates that no program function preceded it.
{02}	Illegal Data Address	The data address received in the query is not an allowable address for EUP1222.
{03}	Illegal Data Value	A value contained in the query data field is not an allowable value for the EUP1222.

Message Sample:

Structure of command message (Byte Format)

Device Address		(0A) h
Function Code		(01) h
Beginning address of coils	MSB	(04) h
	LSB	(A1) h
Number of coils (N)	MSB	(00) h
	LSB	(01) h
CRC DATA	LSB	(AC) h
	MSB	(63) h

Structure of response message (Byte Format)

Device Address		(0A) h
Function Code		(81) h
Error Code		(02) h
CRC DATA	LSB	(B0) h
	MSB	(53) h

As you see in command message,coil information of (4A1) h = 1185 is required but there isn't any coil with 1185 address. Therefore error code with number (02) (Illegal Data Address) sends.

NFC



EndaLink, is a mobile application that provides fast and secure data sharing between NFC supported ENDA devices and mobile devices.

⚠ To communicate with an NFC supported ENDA device, your mobile device must have NFC support.



You can scan the QR codes below to access our EndaLink application on Google Play and the App Store.

Google Play



App Store



Resetting the NFC Password via EndaLink

When the NFC password reset command is sent via EndaLink, the NFC LED on the device starts flashing. If the NFC password reset is successful, the NFC LED will stay on steadily for 3 seconds without flashing. If the reset operation fails, the NFC LED will continue to flash and will not stay on steadily.