



Please read this document carefully before using this product. The guarantee will be invalidated if the device is damaged by not following instructions detailed in the manual. The company shall not be responsible for any damage or losses however caused, which may be experienced as a result of the installation or use of this product.

ENDA EU4430 PID UNIVERSAL CONTROLLER

Thank you for choosing ENDA EU4430 Universal Controller Devices.

- ▶ 48x48mm sized.
- ▶ Dual setpoint value can be selected.
- ▶ PT100 ,J, K, L, T, S, R sensor (thermocouple) types can be selected.
- ▶ 0-20mA, 4-20mA, 0-10V, 2-10V, 0-25mV and 0-50mV input selections.
- ▶ Auto calculation for PID parameters (SELF TUNE).

Self tune for automatic PID calculation or manually enter PID parameters if known.

- ▶ Three different feature can be assigned to digital input.
- ▶ Three different feature can be assigned to F function key.
- ▶ Soft-Start feature.
- ▶ Analogue, SSR or Relay Output Control selection.
- ▶ 0-20mA and 4-20mA Analogue Output Control selection.
- ▶ A1 Relay output programmable as primary Alarm or PID Cooling Control output.
- ▶ C/A2 Relay output can be used as secondary Alarm or Temperature Control output.
- ▶ Heating/Cooling control selection.
- ▶ Zero point input shift.
- ▶ In case of sensor failure, periodically, auto-periodically running or relay state can be selected.
- ▶ RS485 Modbus RTU communication protocol feature (Specify at order).



RoHS
Compliant



Order Code : EU4430 - -

1- Supply Voltage
UV.....90-250V AC

LV.....10-30V DC /
8-24V AC

2- Modbus
RS..... Modbus
(Specify at order)

⚠ Please see EU4430 Modbus Address
Map and Connection Diagram Guide for
Modbus feature.

Input Type		Scale Range		Accuracy
		°C	°F	
PT100 Resistance Thermometer	EN 60751	-199.9...600.0 °C	-199.9...999.9 °F	± 0,2% (for full scale) ± 1 digit
PT100 Resistance Thermometer	EN 60751	-200...600 °C	-328....1112 °F	± 0,2% (for full scale) ± 1 digit
J (Fe-CuNi) Thermocouple	EN 60584	-30.0....600.0 °C	-22.0....999.9 °F	± 0,5% (for full scale) ± 1 digit
J (Fe-CuNi) Thermocouple	EN 60584	-30....600 °C	-22....1112 °F	± 0,5% (for full scale) ± 1 digit
K (NiCr-Ni) Thermocouple	EN 60584	-30.0....999.9 °C	-22.0....999.9 °F	± 0,5% (for full scale) ± 1 digit
K (NiCr-Ni) Thermocouple	EN 60584	-30....1300 °C	-22....2372 °F	± 0,5% (for full scale) ± 1 digit
L (Fe-CuNi) Thermocouple	DIN 43710	-30.0....600.0 °C	-22.0....999.9 °F	± 0,5% (for full scale) ± 1 digit
L (Fe-CuNi) Thermocouple	DIN 43710	-30....600 °C	-22....1112 °F	± 0,5% (for full scale) ± 1 digit
T (Cu-CuNi) Thermocouple	EN 60584	-30.0....400.0 °C	-22.0....752.0 °F	± 0,5% (for full scale) ± 1 digit
T (Cu-CuNi) Thermocouple	EN 60584	-30....400 °C	-22....752 °F	± 0,5% (for full scale) ± 1 digit
S (Pt10Rh-Pt) Thermocouple	EN 60584	-40...1700 °C	-40....3092 °F	± 0,5% (for full scale) ± 1 digit
R (Pt13Rh-Pt) Thermocouple	EN 60584	-40...1700 °C	-40....3092 °F	± 0,5% (for full scale) ± 1 digit
0-20mA input		-1999...+9999 (max. scale range 10000)		± 0,2% (for full scale) ± 1 digit
4-20mA input		-1999...+9999 (max. scale range 10000)		± 0,2% (for full scale) ± 1 digit
0-10V input		-1999...+9999 (max. scale range 10000)		± 0,2% (for full scale) ± 1 digit
2-10V input		-1999...+9999 (max. scale range 10000)		± 0,2% (for full scale) ± 1 digit
0-25mV input		-1999...+9999 (max. scale range 10000)		± 0,2% (for full scale) ± 1 digit
0-50mV input		-1999...+9999 (max. scale range 10000)		± 0,2% (for full scale) ± 1 digit

ENVIRONMENTAL CONDITIONS

Ambient/storage temperature	0 ... +50°C/-25 ... +70°C
Max. Relative humidity	Relative humidity 80% for temperatures up to 31°C decreasing linearly to 50% relative humidity at 40°C.
Rated pollution degree	According to EN 60529; Front panel : IP65, Rear panel : IP20
Height	Max. 2000m

⚠ KEEP AWAY device from exposed to corrosive, volatile and flammable gases or liquids and DO NOT USE the device in similar hazardous locations.

ELECTRICAL CHARACTERISTICS

Supply	90-250V AC 50/60Hz,10-30V DC / 8-24V AC SMPS
Power consumption	Max. 5VA
Wiring	Power screw-terminal connections: 2.5mm ² , Signal screw-terminal connections: 1,5mm ² .
Line resistance	Max. 100 Ohm
Data retention	EEPROM (minimum 10 years)
EMC	EN 61326-1: 2013 (Performance criterion B satisfied for EN 61000-4-3 standard).
Safety requirements	EN 61010-1: 2010 (Pollution degree 2, overvoltage category II)

OUTPUTS

C/A2 Output	Relay : 250V AC, 10A (for resistive load), NO+NC (Control or Alarm2 Output selection).
A1 Output	Relay : 250V AC, 5A (for resistive load), NO (Alarm1 and Cooling Control Output selection).
ANL/SSR Output	Max. SSR Output ; 0-20mA, 4-20mA, 24V 20mA. Max. load resistance ; 600 Ohm (12 bit 0.2% accuracy).
Life expectancy for relay	Without load 30.000.000 switching; 250V AC, 8A (resistive load) 300.000 switching.

CONTROL

Control type	Single Setpoint and Alarm Control.
Control algorithm	On-Off / P, PI, PD, PID (selection).
A/D converter	14 bit.
Sampling time	Min. 100ms.
Proportional band	Can be adjusted between %0.0 and %100.0 . If Pb=%0.0 , ON-OFF control is selected.
Control period	Can be adjusted between 1 and 125secs.
Hysteresis	Can be adjusted between 1 and 50°C/F.
Output power	Setpoint value ratio can be adjusted between %0 and %100 .

HOUSING

Housing type	Suitable for flush-panel mounting according to DIN 43 700.
Dimensions	W48xH48xD87mm
Weight	Approx. 250g
Enclosure material	Self extinguishing plastics

⚠ Avoid any liquid contact when the device is switched on.
DO NOT clean the device with solvent (thinner, gasoline, acid etc.) and / or abrasive cleaning agents.



SISEL MÜHENDİSLİK ELEKTRONİK SAN. VE TİC. A.Ş.
Sarıfili Mah. Barbaros Cad. No:18 Y.Dudullu 34775
ÜMRANİYE/İSTANBUL-TÜRKİYE
Tel : +90 216 499 46 64 Pbx. Fax : +90 216 365 74 01
url : www.enda.com.tr

DIMENSIONS

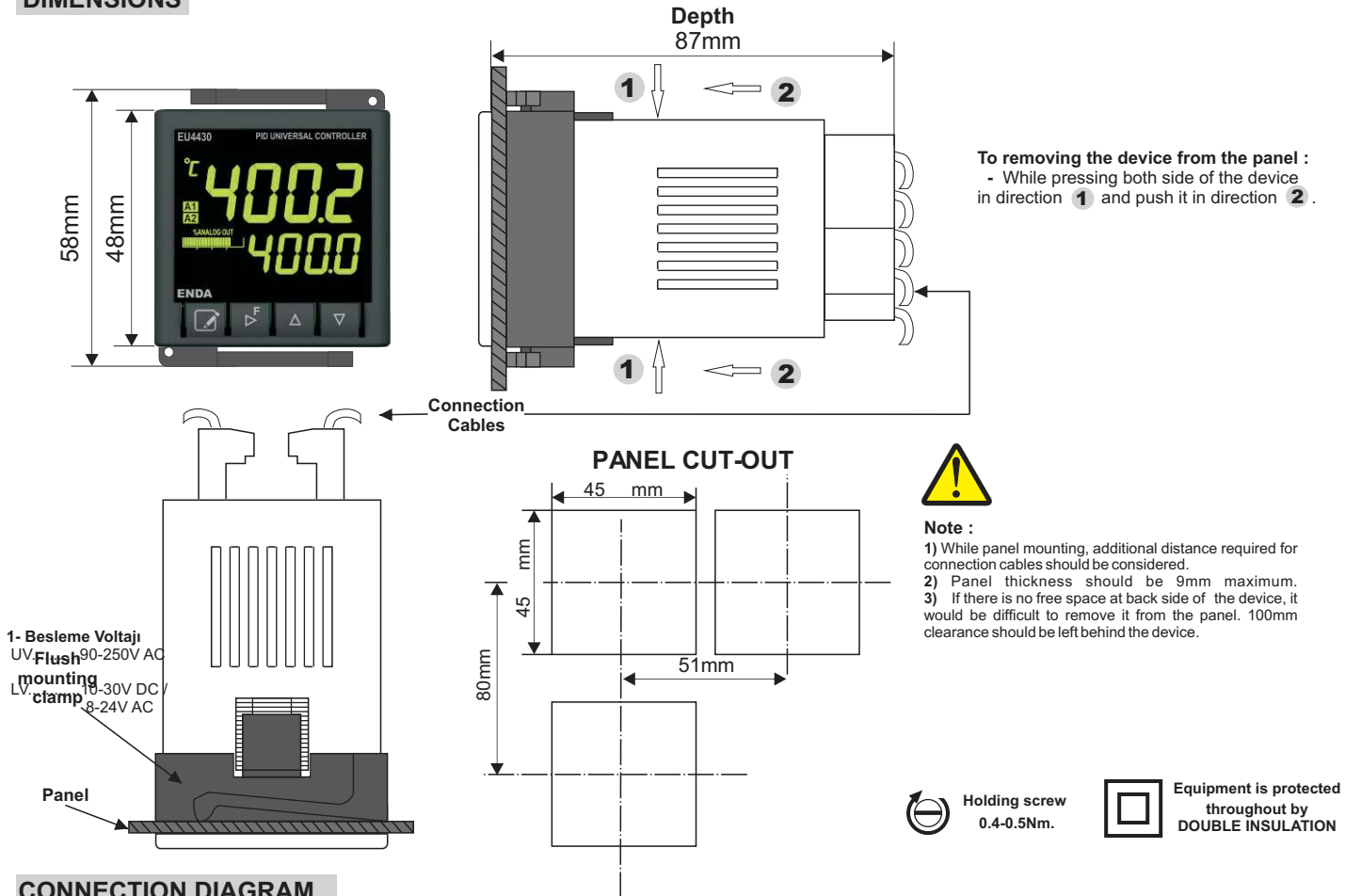

CONNECTION DIAGRAM



END A EU4430 PID Temperature Controllers are intended for installation in control panels. Make sure that the device is used only for intended purpose. The shielding must be grounded on the instrument side. During an installation, all of the cables that are connected to the device must be free of energy. The device must be protected against inadmissible humidity, vibrations, severe soiling. Make sure that the operation temperature is not exceeded. All input and output lines that are not connected to the supply network must be laid out as shielded and twisted cables. These cables should not be close to the power cables or components. The installation and electrical connections must be carried on by a qualified staff and must be according to the relevant locally applicable regulations

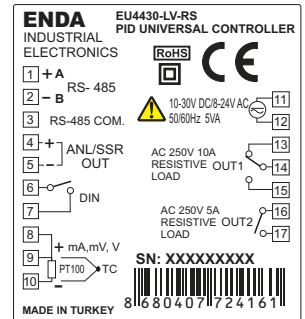
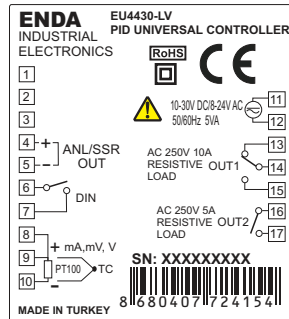
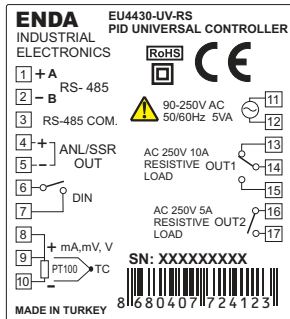
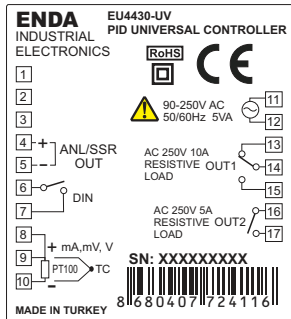

NOTE : SUPPLY VOLTAGE

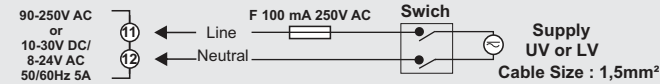

SENSOR INPUT:

For Thermocouples : Use the correct compensating cable. Do not make any supplement to cables. Connect the thermocouple cables to the right places at the input terminal.
For resistance (PT100) Sensor : In order to using 2-wire resistance sensors (PT100), 8th and 9th terminals must be short circuited. Please check connection diagrams carefully.

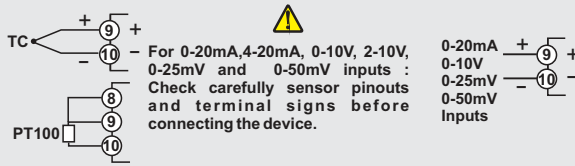

Logic output of the instrument is not electrically insulated from the internal circuits. Therefore, when using a grounding thermocouple, do not connect the logic output terminals to the ground.

Note :

- 1) Mains supply cords shall meet the requirements of IEC 60227 or IEC 60245.
- 2) In accordance with the safety regulations, the power supply switch shall bring the identification of the relevant instrument and it should be easily accessible by the operator.

* MODBUS CONNECTION DIAGRAM

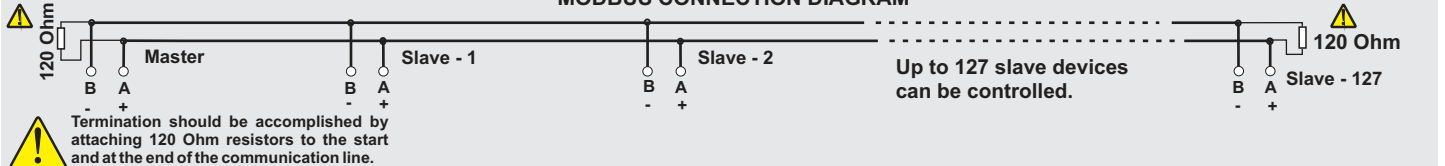

Termination should be accomplished by attaching 120 Ohm resistors to the start and at the end of the communication line.

Please see EUPx420 Series Modbus Address Map and Connection Diagram Guide for Modbus feature.

* Applies to devices with Modbus function.



SISEL MÜHENDİSLİK ELEKTRONİK SAN. VE TİC. A.Ş.
Sarıfili Mah. Barbaros Cad. No:18 Y.Dudullu 34775
ÜMRANİYE/İSTANBUL-TÜRKİYE
Tel : +90 216 499 46 64 Pbx. Fax : +90 216 365 74 01
url : www.enda.com.tr



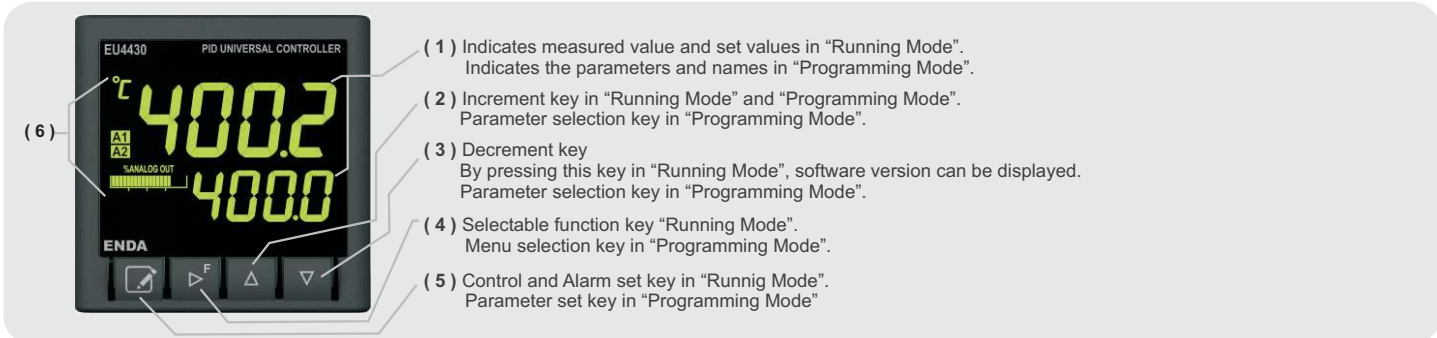

(1) PV and SV Indicators	PV 7 Segment 4 digits green LED , SV 7 Segment 4 digits green LED display.
Character Height	PV Display 12.0mm , SV Display 8.13mm
(2),(3),(4),(5) Keypads	Micro switch
(6) Status Indicators	Control, Alarm1, Alarm2, Analog output, SSR output and status indicator symbols.

ALARM1 AND ALARM2 OUTPUT TYPES

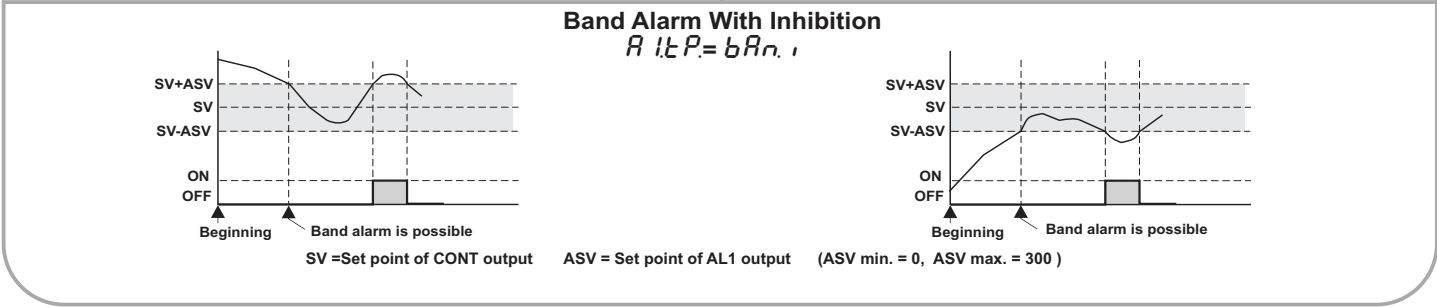
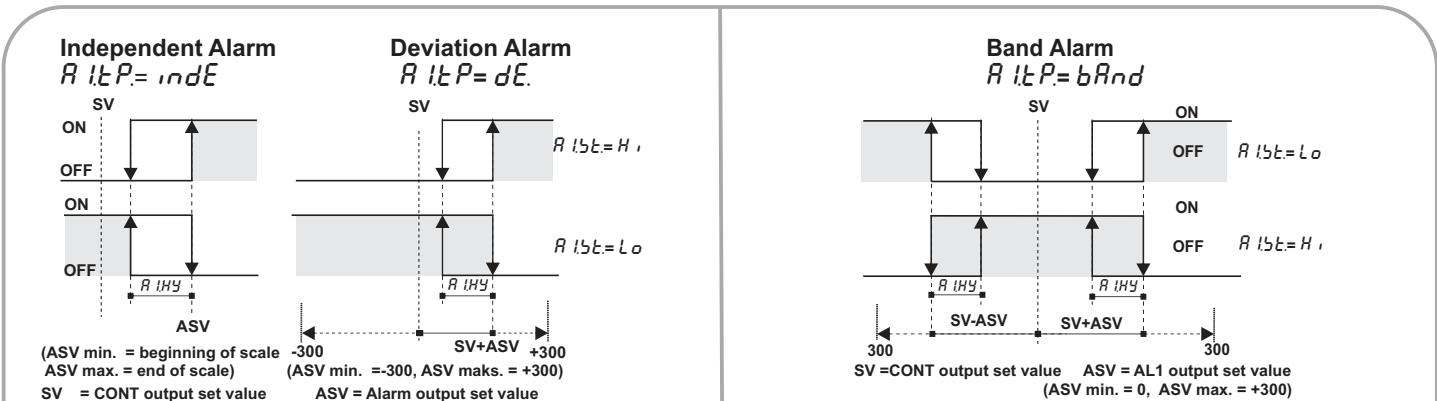

SETTING UP ALARM CONTROL AND SETPOINT VALUES

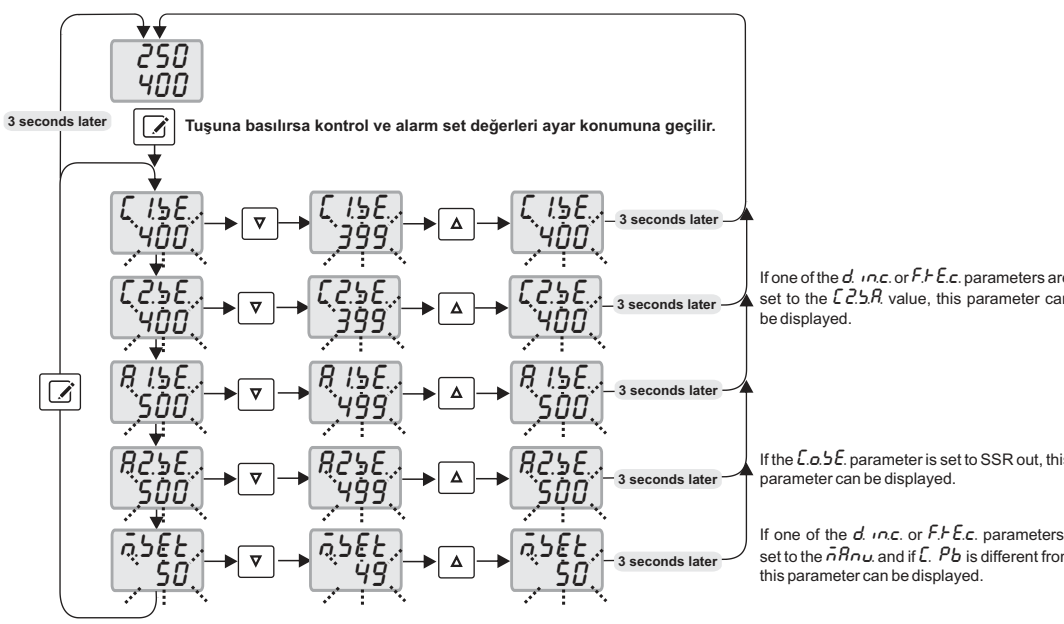

ERROR MESSAGES

PFR 400 No communication with sensor. (Sensor and/or cable broken or not connected)

--- 400 Temperature value is higher than scale.

--- 400 Temperature value is lower than scale.

If one of the d_{inc} or $F.F.E.c$ parameters are set to the $C25R$ value, this parameter can be displayed.

If the $C.a.s.E$ parameter is set to SSR out, this parameter can be displayed.

If one of the d_{inc} or $F.F.E.c$ parameters are set to the $RAnu$ and if $C.Pb$ is different from 0, this parameter can be displayed.

