



Read this document carefully before using this device. The guarantee will be expired by damages if you don't attend to the directions in the user manual. Also we don't accept any compensations for personal injury, material damage or capital disadvantages.

ENDA EDP7041 DIGITAL POTENTIOMETER

Thank you for choosing ENDA EDP7041 Potentiometer.

- ▶ 72x72mm sized.
- ▶ 4 digits display.
- ▶ Easy to use front panel keypad.
- ▶ Communication via RS-485 Modbus protocol or synchronous running between two or more potentiometers (Optional).
- ▶ External preset key feature.
- ▶ Display scale can be adjusted between -1999 and 9999.
- ▶ Decimal point can be set between 1st and 3rd digit.
- ▶ 0-10V,0-20 mA a and 4-20mA output with adjustable minimum and maximum values.
- ▶ Soft ON / Soft OFF feature.
- ▶ Parameter access protection.
- ▶ CE marked according to European Norms.



RoHS
Compliant



Order Code : EDP7041 -

--	--	--	--

--	--

1- Supply
UV.....90-250V AC

LV.....10-30V DC /
8-24V AC

2- Modbus
RS... Modbus
(Specify at Order)

TECHNICAL SPECIFICATIONS

ENVIRONMENTAL CONDITIONS	
Ambient/storage temperature	0 ... +50°C/-25 ... +70°C (without icing)
Max. relative humidity	80% Relative humidity for temperatures up to 31 % °C, decreasing linearly to 50% at 40°C.
Rated pollution degree	According to EN 60529 Front panel : IP65 Rear panel : IP20
Height	Max. 2000m
Do not use the device in locations subject to corrosive and flammable gases.	
ELECTRICAL CHARACTERISTICS	
Supply	90-250V AC 50/60Hz; 10-30V DC / 8-24V AC SMPS
Power consumption	Max. 7VA
Wiring	2.5mm ² Screw Connections
Date retention	EEPROM (Min. 10 years)
EMC	EN 61326-1: 2013 (Performance criterion B for the EMC standards)
Safety requirements	EN 61010-1: 2010 (pollution degree 2, overvoltage category II, measurement category I)
INPUTS	
Upwards input (UP)	Contact input or max. 24VDC logic input (active low)
Downwards input (DOWN)	Contact input or max. 24VDC logic input (active low)
OUTPUT	
0-10V output	Digitally adjusted maximum 10mA, max. 10V potentiometer output. Accuracy : %0.1 Resolution : 1mV Fluctuation : Maximum 30mV Rise time from 0 to 10V is maximum 300ms
0-20mA output	Digitally adjusted maximum 12V, max.20 mA potentiometer output. Accuracy : %0.1 Resolution : 2µA Fluctuation : Maximum 60µA Rise time from 0 to 20mA is maximum 300ms
HOUSING	
Housing type	Suitable for flush-panel mounting according to DIN 43 700.
Dimensions	W72xH72xD97mm
Weight	Approx. 350g (after packing)
Enclosure material	Self extinguishing plastics
While cleaning the device, solvents (thinner, gasoline, acid etc.) or corrosive materials must not be used.	

FRONT PANEL DESCRIPTIONS AND FEATURES

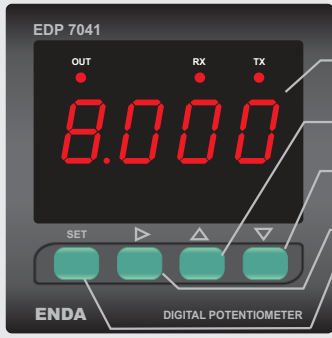

- 1) In "Running Mode", indicates the potentiometer set value.
In "Programming Mode", indicates the parameter name, parameter value and/or parameter unit.
- 2) In "Running Mode", increases the set value and used for "Output ON" key.
In "Programming Mode", increases the set value and used for parameter selection.
- 3) In "Running Mode", decreases the set value and used for "Output OFF" key.
In "Programming Mode", decreases the set value and used for parameter selection.
- 4) In "Programming Mode", used for menu selection.
- 5) Used for mode selections and set parameters.

(1) Digital Display	4 Digits 7 Segment red LED display
Character Height	14.2mm
(2),(3),(4),(5) Keypad	Micro switch

DIMENSIONS

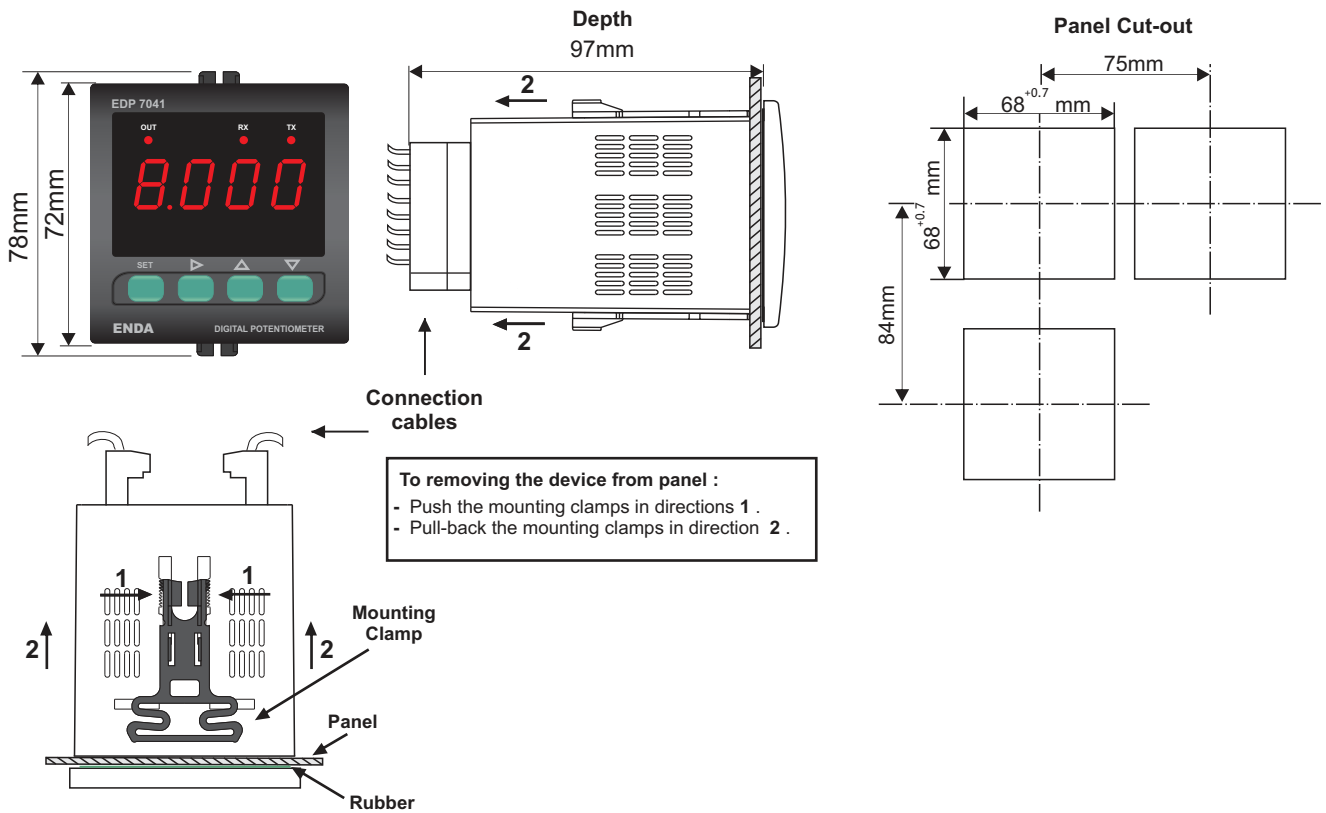

Note :

- 1) While panel mounting, additional distance required for connection cables should be considered.
- 2) Panel thickness should be maximum 10mm.
- 3) If there is no 90mm free space at back side of the device, it would be difficult to remove it from the panel.

CONNECTION DIAGRAM



ENDA EDP7041 is intended for installation in control panels. Make sure that the device is used only for intended purpose. The electrical connections must be carried out by a qualified staff and must be according to the relevant locally applicable regulations. During an installation, all of the cables that are connected to the device must be free of electrical power. The device must be protected against inadmissible humidity, vibrations, severe soiling. Make sure that the operation temperature is not exceeded. The cables should not be close to the power cables or components.

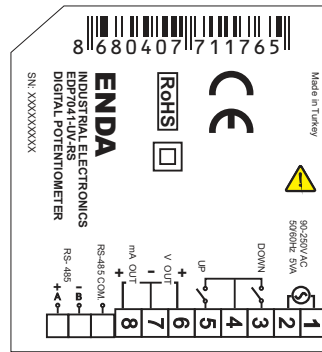
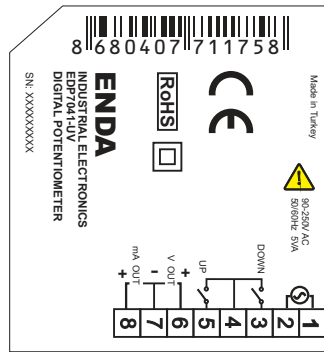

Note :

- 1) Mains supply cords shall meet the requirements of IEC 60227 or IEC 60245.
- 2) In accordance with the safety regulations, the power supply switch shall bring the identification of the relevant instrument and it should be easily accessible by the operator.

NOTE :

SUPPLY :

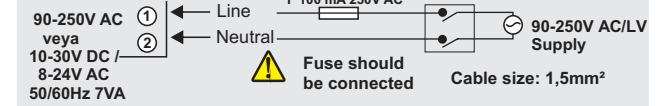

Equipment is protected throughout by DOUBLE INSULATION.

Holding screw 0.4-0.5Nm

RoHS Compliant

CONNECTION DIAGRAM FOR SYNCHRONOUS RUNNING

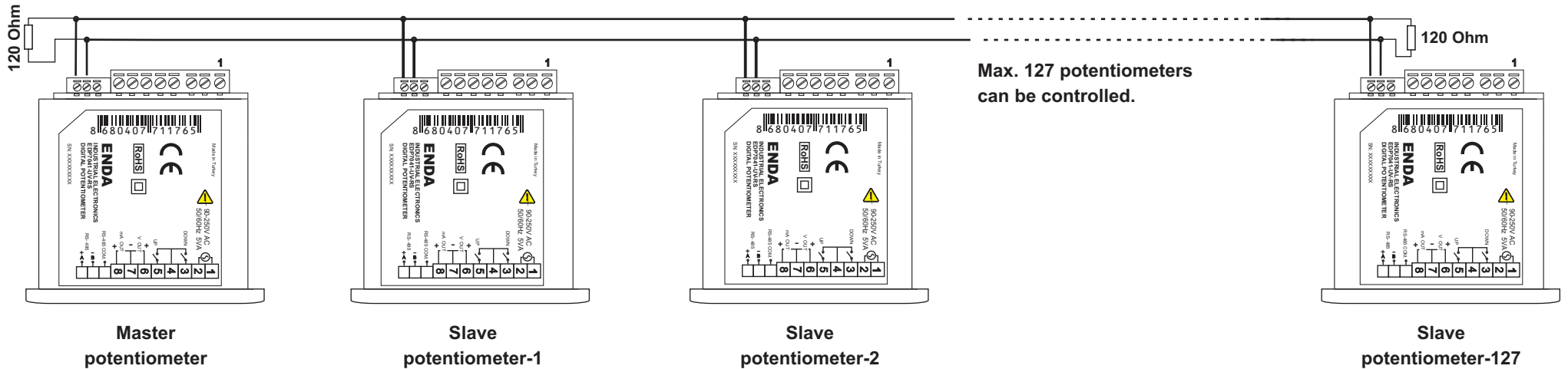

NOTE :

- *dRdr* parameter should be selected *CPot* in master potentiometer. In this case *dRdr* parameter of other potentiometers aren't used. But be sure that *CPot* isn't selected in slave potentiometers to prevent confusion. Settings of slave potentiometers change proportional to setting of master potentiometer. For example; When Max. output of master potentiometer is changed from 10V to 5V, max. output of slave potentiometers decrease half of previous value proportional to this. If previous output of slave potentiometer is 6V, it decreases 3V. *Ponnc* parameter of slave potentiometer should be selected *OFF* in order to understand master potentiometer when slave is energized.

- Computer should be used to change only a few potentiometers. In this case, there is not master potentiometer. Output of the required potentiometer is changed according to *dRdr* parameter.

- Baud rate of potentiometers must be same in both conditions. 120 Ohm termination resistor should be used at the ends and beginning of transmission line.



SİSEL MÜHENDİSLİK ELEKTRONİK SAN. VE TİC. A.Ş.
Şerifali Mah. Barbaros Cad. No:18 Y.Dudullu 34775
ÜMRANİYE/İSTANBUL-TURKEY
Tel : +90 216 499 46 64 Pbx. Fax : +90 216 365 74 01
url : www.enda.com.tr

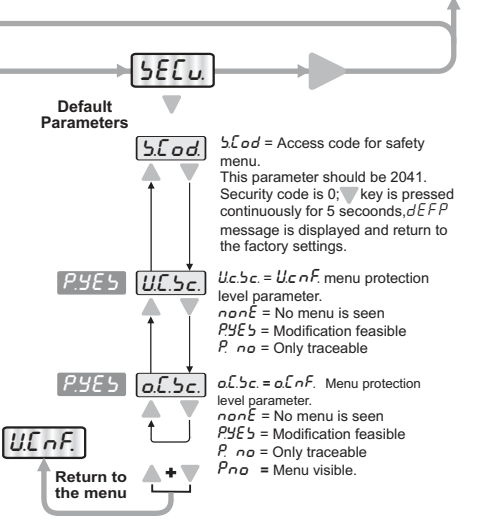
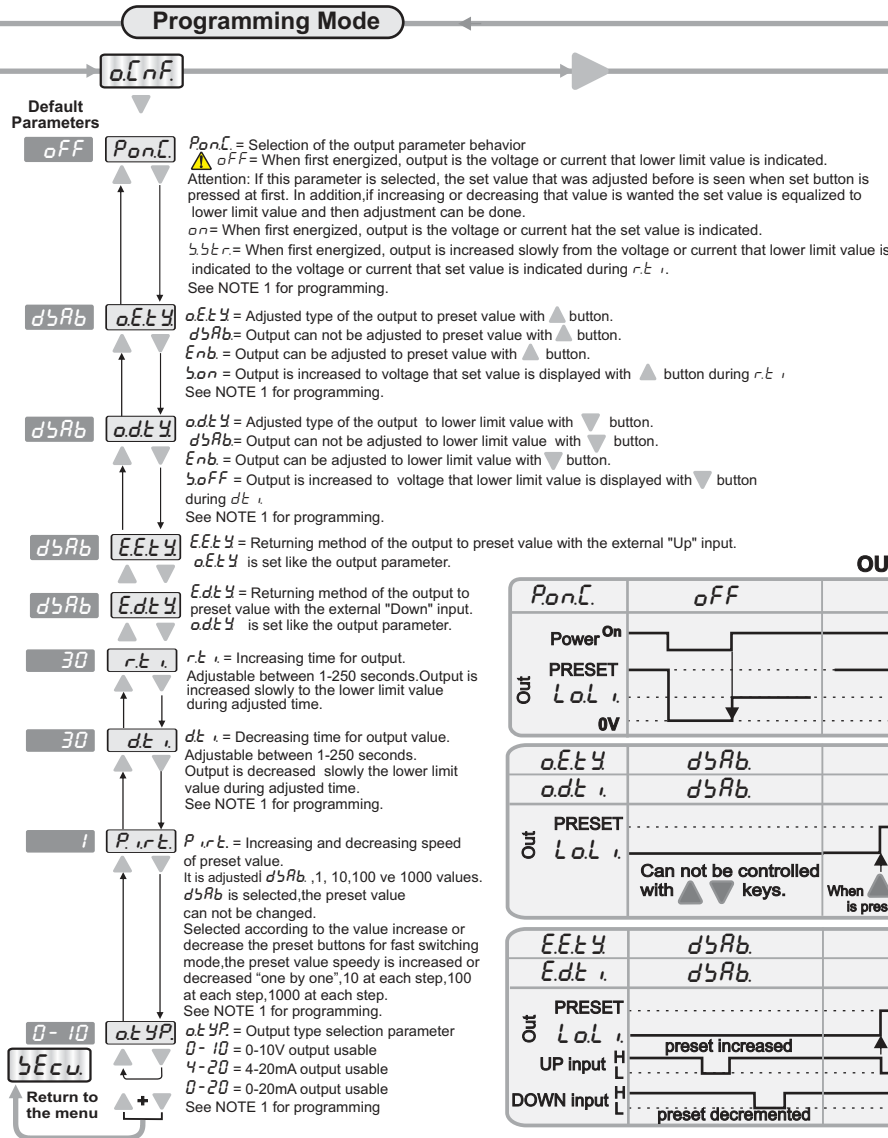
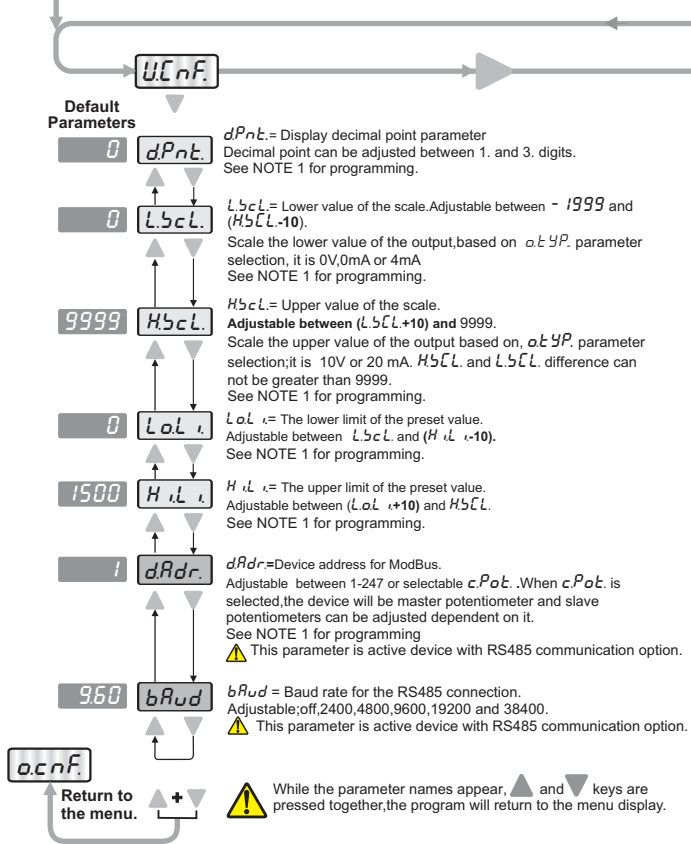
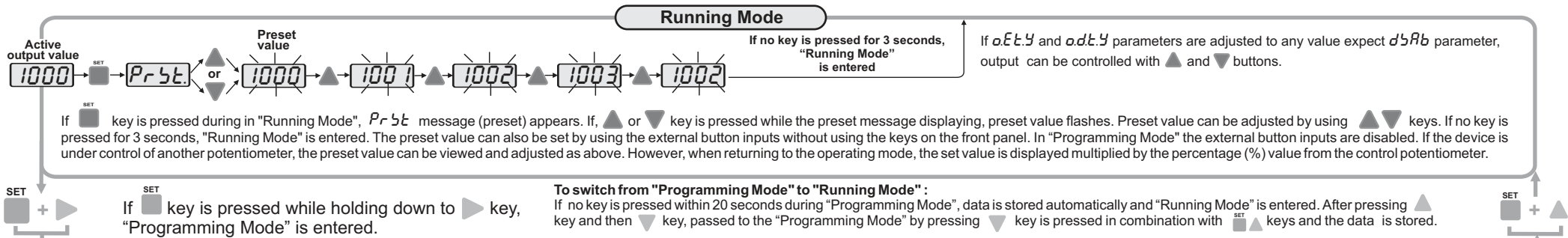

NOTE 1 Parameter adjustment method

To adjusting a selected parameter, first press and hold **SET** key. Then, by using **▲** **▼** keys, adjustment can be performed.

If increment key **▲** is pressed and held 0.6 seconds, the value of the selected parameter changes rapidly. If waited enough, the value increases 100 at each step. After 1 second following the release of the key, initial condition is returned. The same procedure is valid for the decrement key.

OUTPUT DIAGRAM

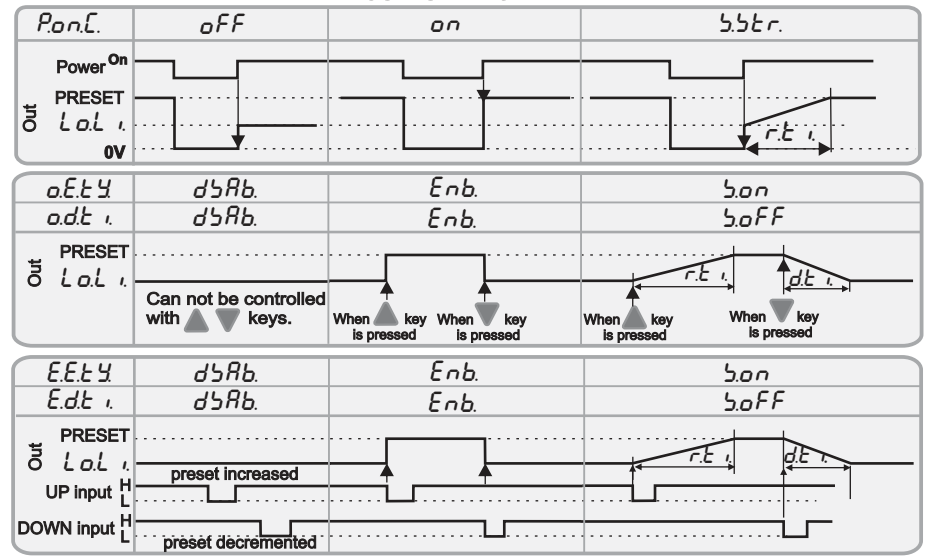

ENDA EDP7041 DIGITAL POTENTIOMETER

MODBUS PROTOCOL ADDRESS MAP

1.1 Memory Map for Holding Registers

Parameter Number	Holding Register addresses Decimal (Hex)	Data Type	Data Content	Parameter Name	Read/Write Permission	Default Parameters
H0	0000d (0000h)	Word	Percentage of the external control. Adjustable between %0.00 and %100.0		R / W	10000
H1	0001d (0001h)	Word	Preset value	<i>PrSt.</i>	R / W	1000
H2	0002d (0002h)	Word	Decimal point	<i>dPnt.</i>	R / W	0
H3	0003d (0003h)	Word	The lower value of the scale	<i>L5CL.</i>	R / W	0
H4	0004d (0004h)	Word	The upper value of the scale	<i>H5CL.</i>	R / W	9999
H5	0005d (0005h)	Word	The lower limit of the preset value	<i>LoLi.</i>	R / W	0
H6	0006d (0006h)	Word	The upper limit of the preset value	<i>HiLi.</i>	R / W	2000
H7	0007d (0007h)	Word	Device address for Rs485 network connection (Adjustable between 1-247.) If set to "0", the control potentiometer mode is entered.	<i>dAdr.</i>	R / W	1
H8	0008d (0008h)	Word	Baud rate selection (0= None; 1=2400bps ; 2=4800bps ; 3=9600bps ; 4=19200bps; 5=38400bps)	<i>bAud.</i>	R / W	3
H9	0009d (0009h)	Word	The first opening the control parameter 0= <i>oFF</i> , 1= <i>on</i> , 2= <i>55Er</i>	<i>PonC.</i>	R / W	0
H10	0010d (000Ah)	Word	Output upper arrow button to fetch the value of the preset selection 0= <i>d5Rb</i> , 1= <i>Enb</i> , 2= <i>5on</i>	<i>oEtY</i>	R / W	0
H11	0011d (000Bh)	Word	Output lower arrow button to fetch the value of the lower limit selection 0= <i>d5Rb</i> , 1= <i>Enb</i> , 2= <i>5oFF</i>	<i>oLtY</i>	R / W	0
H12	0012d (000Ch)	Word	Time to increase the output voltage	<i>r.t.</i>	R / W	30
H13	0013d (000Dh)	Word	Time to decrease the output voltage	<i>dt.</i>	R / W	30
H14	0014d (000Eh)	Word	Preset the value of the increment and decrement rate or cancel the setting 0 = cancel, 1=1, 2=10, 3=100, 4=1000.	<i>P. idt.</i>	R / W	1
H15	0015d (000Fh)	Word	Output type selection parameter 0 = 0-10V output, 1 = 4-20mA output, 2 = 0-20mA output	<i>o.tYP.</i>	R / W	0
H16	0016d (0010h)	Word	User security parameter configuration menu (0 = Menu invisible, 1= Menu programmable, 2 or 3 = Menu only traceable).	<i>UC5C.</i>	R / W	1
H17	0017d (0011h)	Word	Output security parameter configuration menu (0 = Menu invisible, 1= Menu programmable, 2 or 3 = Menu only traceable).	<i>oC5C.</i>	R / W	1
H18	0018d (0012h)	Word	Function control parameter (23040d (5A00h) value is entered, any function executed. (23041d (5A01h) value is entered, the default values will be restored.		R / W	0
H19	0019d (0010h)	Word	Returning method of the output to preset value with the external "Up" input. 0 = <i>d5Rb</i> , 1 = <i>Enb</i> , 2 = <i>5on</i>	<i>EEtY</i>	R / W	0
H20	0020d (0011h)	Word	Returning method of the output to preset value with the external "Down" input. 0 = <i>d5Rb</i> , 1 = <i>Enb</i> , 2 = <i>5oFF</i>	<i>E.d.t.Y</i>	R / W	0

1.2 Memory Map for Coils

Parameter Number	Input Register addresses Decimal (Hex)	Data Type	Data Content	Parameter Name	Read/Write Permission	Default Parameters
I0	0000d (0000h)	Word	Instant set value	■■■	R	■■■
I1	0001d (0001h)	Word	% of value the analog output (%0.00-%100.00 sensitivity)	■■■	R	■■■

1.3 Memory Map for Discrete Input

Parameter Number	Discrete input addresses	Data Type	Data Content	Parameter Name	Read/Write Permission	Default Parameters
D0	(0000)h	Bit	State of the external down button (0 = OFF , 1 = ON)	■■■	R	■■■
D1	(0001)h	Bit	State of the external up button (0 = OFF , 1 = ON)	■■■	R	■■■

2. MODBUS ERROR MESSAGES

Modbus protocol has two types error, communication error and operating error. Reason of the communication error is data corruption in transmission. Parity and CRC control should be done to prevent communication error. Receiver side checks parity and CRC of the data. If they are wrong, the message will be ignored. If format of the data is true but function doesn't perform for any reason, operating error occurs. Slave realizes error and sends error message. Most significant bit of function is changed '1' to indicate error in error message by slave. Error code is sent in data section. Master realizes error type via this message.

ModBus Error Codes

Error Code	Name	Description
{01}	ILLEGAL FUNCTION	The function code received in the query is not an allowable action for the slave. If a Poll Program Complete command was issued, this code indicates that no program function preceded it.
{02}	ILLEGAL DATA ADDRESS	The data address received in the query is not an allowable address for the slave.
{03}	ILLEGAL DATA VALUE	A value contained in the query data field is not an allowable value for the slave.

Message example:

Structure of command message (Byte Format)

Device Address	(0A)h
Function Code	(01)h
Beginning address of coils.	MSB (04)h
	LSB (A1)h
Number of coils (N)	MSB (00)h
	LSB (01)h
CRC DATA	LSB (AC)h
	MSB (63)h

Structure of response message (Byte Format)

Device Address	(0A)h
Function Code	(81)h
Error Code	(02)h
CRC DATA	LSB (B0)h
	MSB (53)h

As you see in command message, coil information of (4A1)h = 1185 is required but there isn't any coil with 1185 address. Therefore error code with number (02) (Illegal Data Address) sends.