



Read this document carefully before using this device. The guarantee will be expired by damaging of the device if you don't attend to the directions in the user manual. Also we don't accept any compensations for personal injury, material damage or capital disadvantages.

# ENDA EC442 UP/DOWN COUNTER

Thank you for choosing ENDA EC442 COUNTER.

- \* 48x48mm sized.
- \* 2x4 digits display.
- \* Easy to use by front panel keypad.
- \* Counting up and down with a 2 channel inputs having a 90° phase shift.
- \* Input frequency can be selectable.
- \* Prescaler factor can be adjusted between 0.001 and 9.999.
- \* Decimal point can be adjusted between 1. and 3. digits.
- \* Sensor type can be selected as PNP, NPN or Encoder.
- \* Single set-point control is made by a single relay output.
- \* Output can be energized continuously or just for a time interval of 0.1 to 999.9 seconds.
- \* Selectable functional reset input.
- \* Input offset feature.
- \* Parameter access protection on 3 levels.
- \* Easy connection by removable screw terminal.
- \* CE marked according to European Norms.



**RoHS  
Compliant**



Order Code : EC442-□□□□□□

1

**Supply Voltage**  
230VAC...230V AC  
24VAC.....24V AC  
SM.....9-30V DC / 7-24V AC

## TECHNICAL SPECIFICATIONS

ENVIRONMENTAL CONDITIONS	
Ambient/storage temperature	0 ... +50°C/-25 ... +70°C (with no icing)
Max. relative humidity	80% up to 31°C decreasing linearly 50% at 40°C.
Rated pollution degree	According to EN 60529      Front panel : IP60 Rear panel : IP20
Height	Max. 2000m
Do not use the device in locations subject to corrosive and flammable gases.	

ELECTRICAL CHARACTERISTICS	
Supply	230V AC +10% -20% or 24V AC ±10%, 50/60Hz or optional 9-30V DC / 7-24V AC ±10% SMPS module.
Power consumption	Max. 5VA
Wiring	2.5mm² screw-terminal connections
Date retention	EEPROM (Min. 10 years)
EMC	EN 61326-1: 1997, A1: 1998, A2: 2001 (Performance criterion B for the EMC standard)
Safety requirements	EN 61010-1: 2001 (pollution degree 2, overvoltage category II)

INPUTS	
Count input (CP1, CP2)	2 channels (max. 9999Hz, 5V to 30V pulse)
Frequency (Hz)	25, 500, 1000, 2000, 5000, 7500Hz, 9999Hz (selectable by programming)
Minimum On and Off times for pulses	20ms for f=25Hz 1ms for f=500Hz 500µs for f=1kHz 250µs for f=2kHz 100µs for f=5kHz 67µs for f=7,5kHz 50µs for f=10kHz
Reset input	PNP: Positive reset (5V to 30V pulse with adjustable pulse time between 2ms and 50ms) NPN: GND terminal is connected to the RESET IN terminal.

OUTPUTS	
Control output (OUT)	Relay : 250V AC, 2A (for resistive load), NO+NC Open collector output (S.S. OUT): Max. 30V DC, 100mA
Auxiliary power supply	12V DC, max. 50mA (without regulation)
Life expectancy for relay	Mechanical 30.000.000 operation; Electrical 300.000 operation
Note : Relay and S.S.OUT outputs are in synchronization . When OUT relay is energized S.S. OUT transistor goes into saturation.	

HOUSING	
Housing type	Suitable for flush-panel mounting according to DIN 43 700.
Dimensions	W48xH48xD87mm
Weight	Approx. 210g (after packing)
Enclosure material	Self extinguishing plastics
While cleaning the device, solvents (thinner, benzene, acid etc.) or corrosive materials must not be used.	

# TERMS



- (1) Counting value during run mode.  
Parameter value or mnemonic parameter code during programming mode.
- (2) Preset value during run mode.  
Parameter value, unit or mnemonic parameter code during programming mode.
- (3) Output LED.
- (4) Increment key during run and programming modes.  
Parameter selection key during programming mode.
- (5) Decrement or reset key during run mode.  
Parameter selection or decrement key during programming mode.
- (6) Used for selecting *options* or digits to be changed.
- (7) Used for selecting run or programming modes or for adjusting the parameter.

( 1 ) PV display	4 digits, seven segment red LED
( 2 ) SV display	4 digits, seven segment yellow LED
Character height	PV display (1) : 7.1mm SV display (2) : 7.1mm
( 3 ) Output LED	One red LED
( 4 ), ( 5 ), ( 6 ), ( 7 ) Keypad	Micro switch

## DIMENSIONS

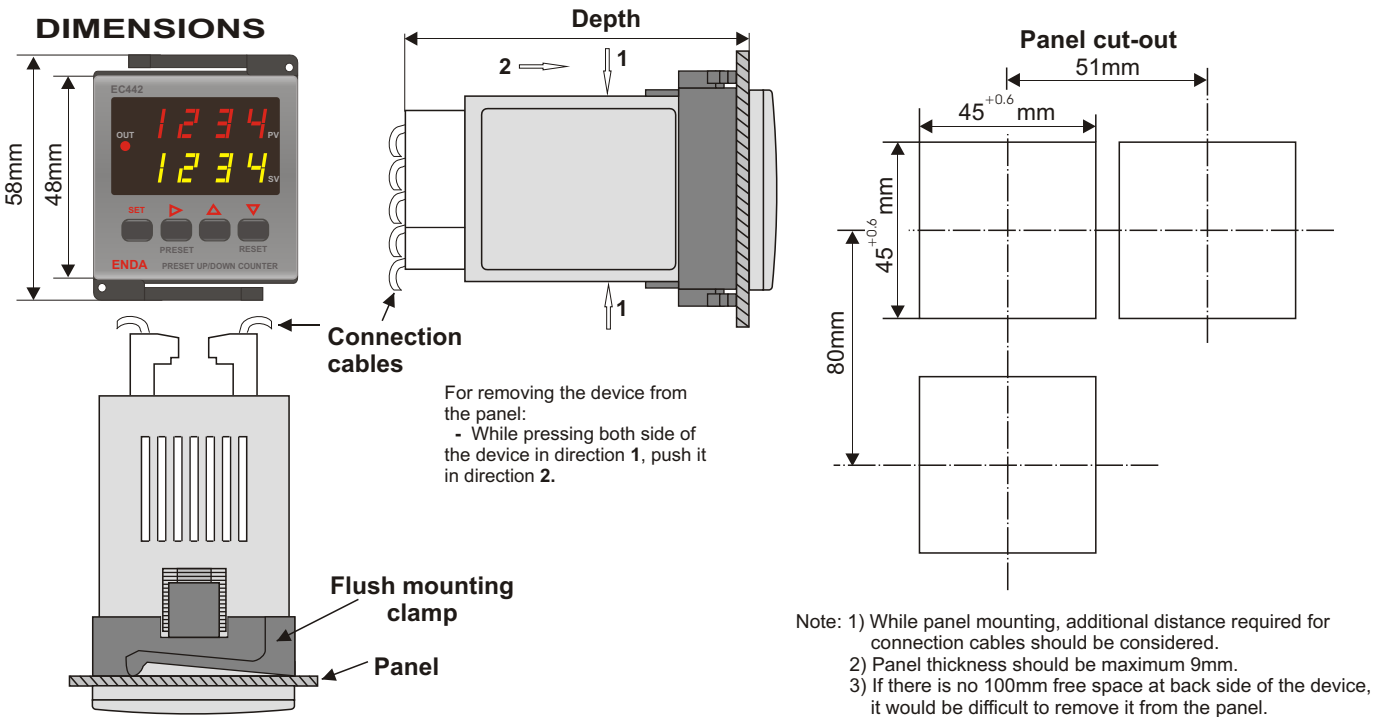

## CONNECTION DIAGRAM



ENDA EC442 is intended for installation in control panels. Make sure that the device is used only for intended purpose. The shielding must be grounded on the instrument side. During an installation, all of the cables that are connected to the device must be free of energy. The device must be protected against inadmissible humidity, vibrations, severe soiling and make sure that the operation temperature is not exceeded. All input and output lines that are not connected to the supply network must be laid out as shielded and twisted cables. These cables should not be close to the power cables or components. The installation and electrical connections must be carried on by a qualified staff and must be according to the relevant locally applicable regulations.

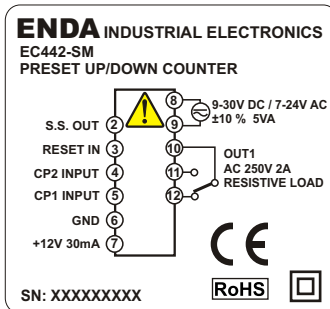
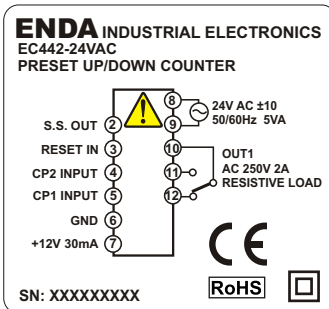
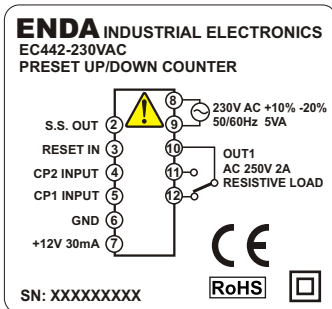

Holding screw 0.4-0.5Nm

Equipment is protected throughout by DOUBLE INSULATION.

### NOTE :

#### SUPPLY:

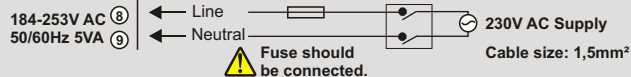

- Note : 1) Mains supply cords shall meet the requirements of IEC 60227 or IEC 60245.  
2) In accordance with the safety regulations, the power supply switch shall bring the identification of the relevant instrument and it should be easily accessible by the operator.

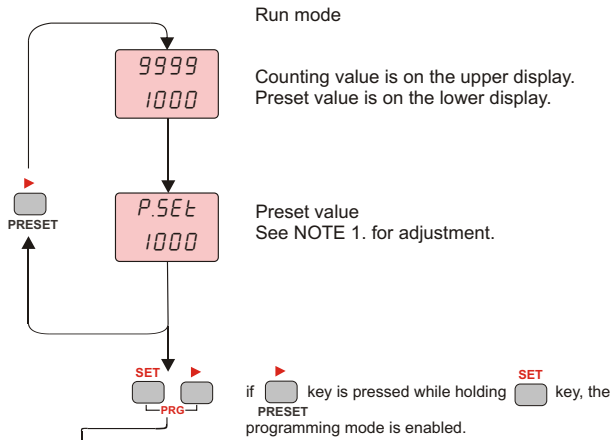

PARAMETER TABLE																		
inPt. opt. 1.	inPt. TYPE	CP1U. CP2d.	CP1U. CP2U.	CP1U. CP2G.	CP1U. CP2r.	UP Ph.4	UP Ph.1	UP Ph.2						dEc. Pnt.	0	00	000	0000
	Cntr. dir.	d irE.	oPPo.											d.SP. CAL.	0001	.....	9999	
	inPt. Frq.	25 Hertz	500 Hertz	1000 Hertz	2000 Hertz	5000 Hertz	7500 Hertz	9999 Hertz						oFFS. dAtA	0	.....	5000	
	SEnS. TYPE	nPn	PnP	Enco.										SECU. code	1111			
OutP. opt. 1.	rSEt PULS	0.002 Sec.	0.005 Sec.	0.010 Sec.	0.020 Sec.	0.050 Sec.								inP.o. SECU.	nonE	PrOG. no	PrOG. YES	
	outP. TYPE	ConF. 1	ConF. 2	ConF. 4	ConF. 5	ConF. 6	ConF. 7	ConF. 8	ConF. 9	ConF. 10				Out.o. SECU.	nonE	PrOG. no	PrOG. YES	
	out t. i.	0000	.....	999.9										d.iS.o. SECU.	nonE	PrOG. no	PrOG. YES	
														Cntr. rSEt	no	PrnE. rSEt	rSEt inPt.	both
														dEF. SEt	no	YES		

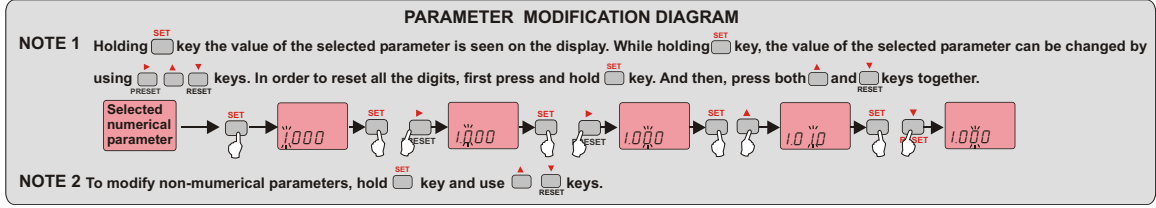
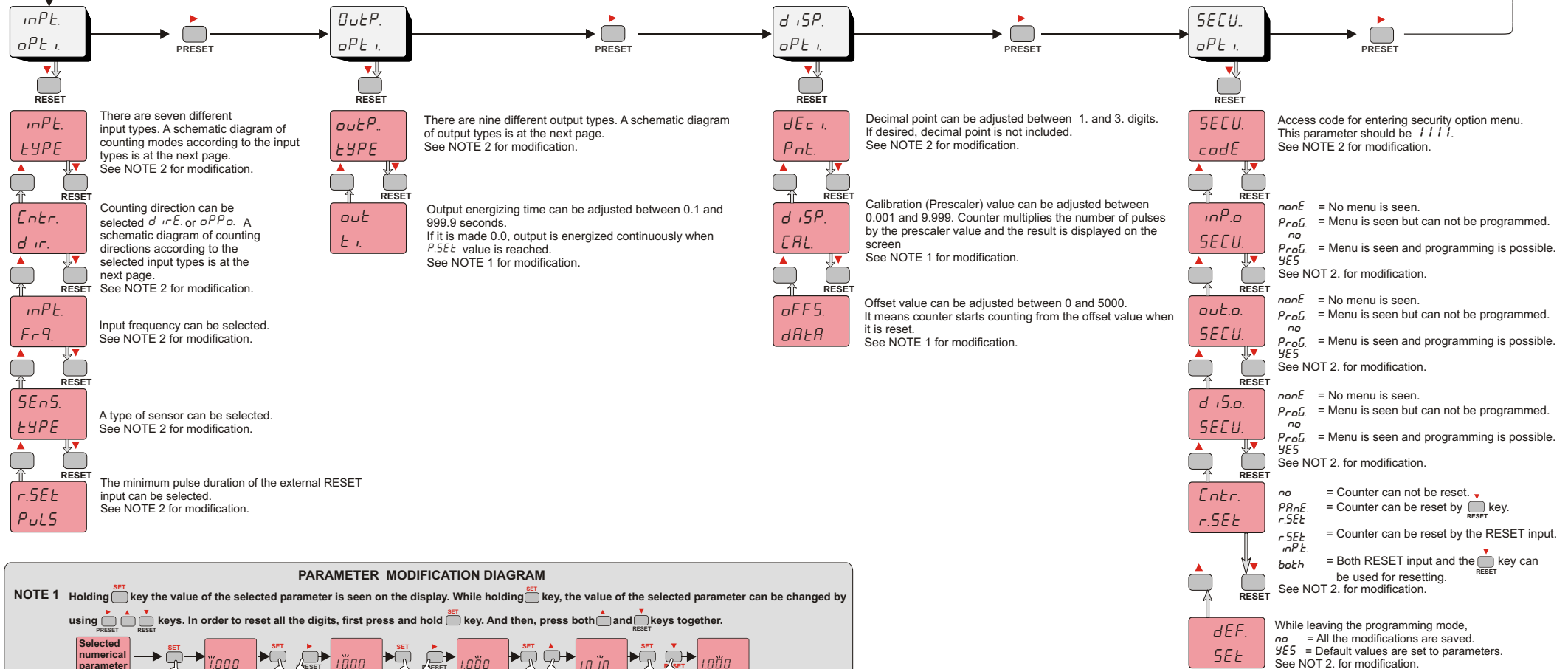

INPUT TYPES

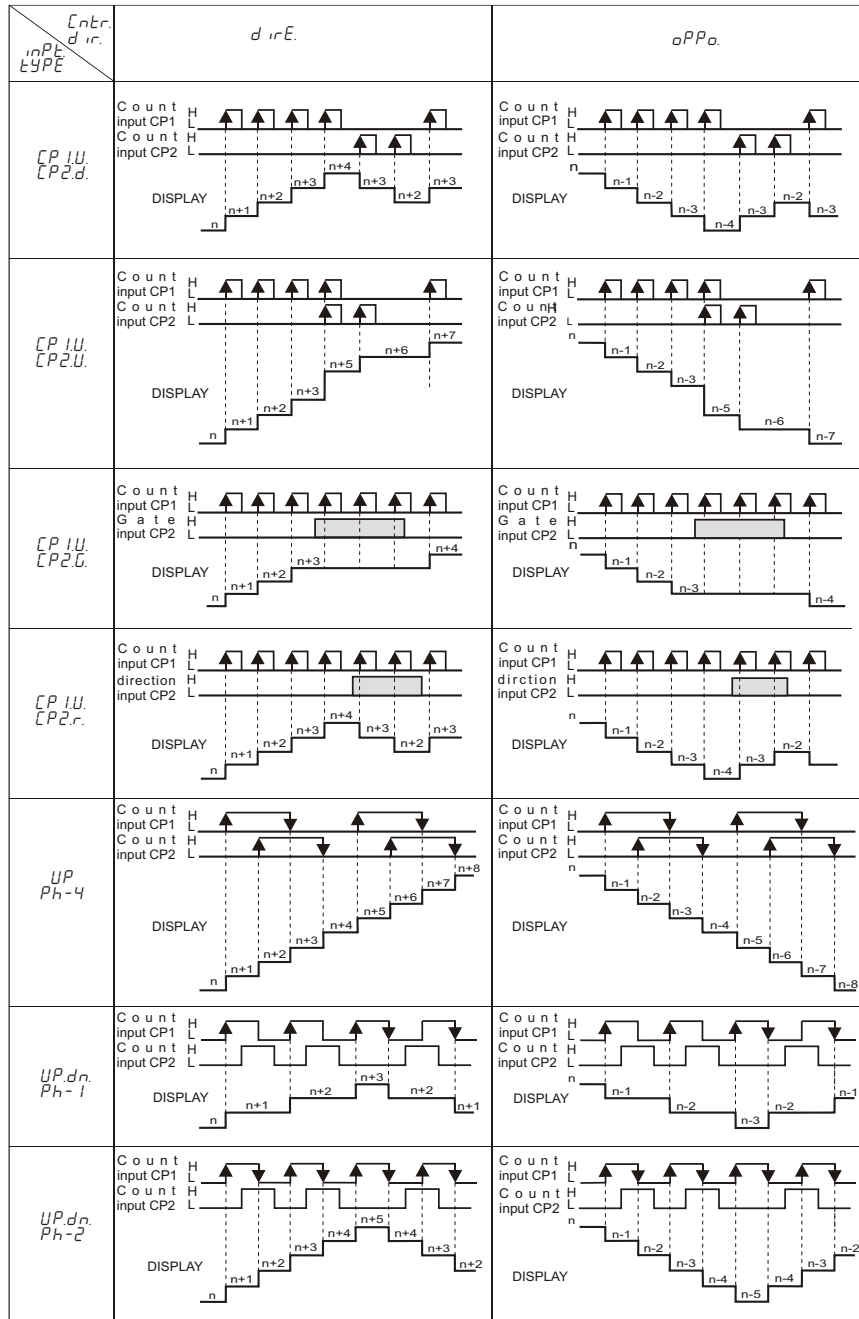

NOTE 1) For PNP sensor, counter is triggered at the rising edge of the pulses.  
 For NPN sensor counter is triggered at the falling edge of the pulses.  
 2) For NPN sensor, if you select  $\text{inPEtype CP1U. CP2r.}$ , above diagram for  $\text{Entr.dir. dirE}$  replaces with  $\text{Entr.dir. oppo.}$

OUTPUT TYPES

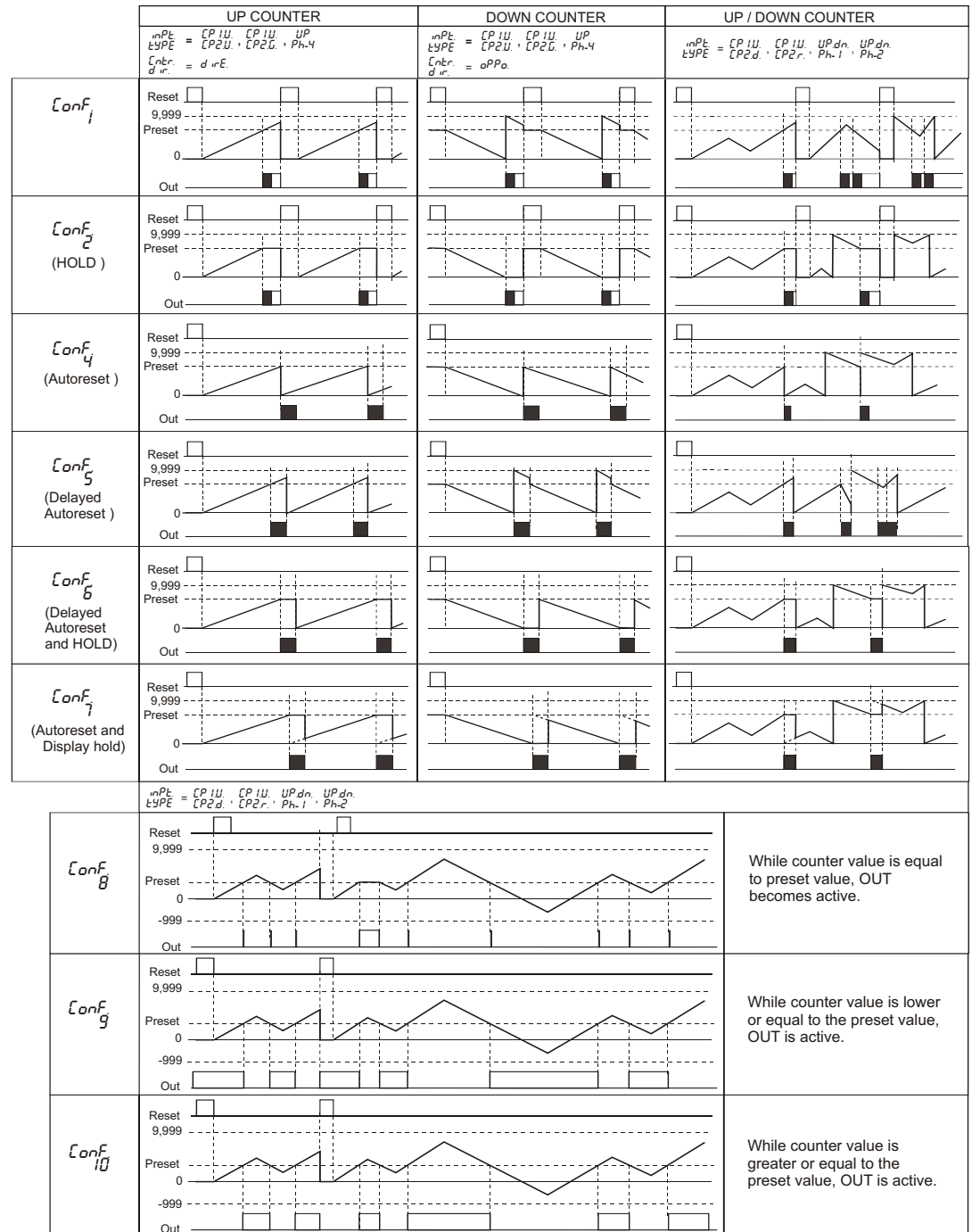

Adjusting  $\text{out} \tau_i$  to a value between 0.1 and 999.9 seconds, a pulse output is obtained.  
 Adjusting  $\text{out} \tau_i$  to 0.0, a continuous output is obtained.

## TERMINAL CONNECTIONS

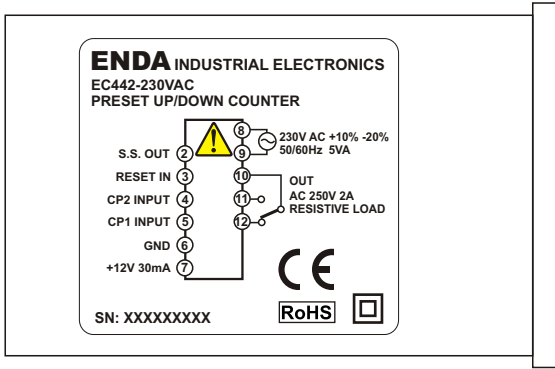

### Terminal descriptions

- 2 : Solid state out (Max 30V 100mA, open collector NPN).
- 3 : Reset input.
- 4 : Input for clock pulse 2 (Max 30V 7.5kHz).
- 5 : Input for clock pulse 1 (Max 30V 7.5kHz).
- 6 : GND.
- 7 : +12V 30mA auxiliary power supply output for sensors.
- 8,9 : SUPPLY inputs.
- 10,11,12 : Relay contacts (Max 2A 250V AC).

## TYPICAL SENSOR CONNECTIONS

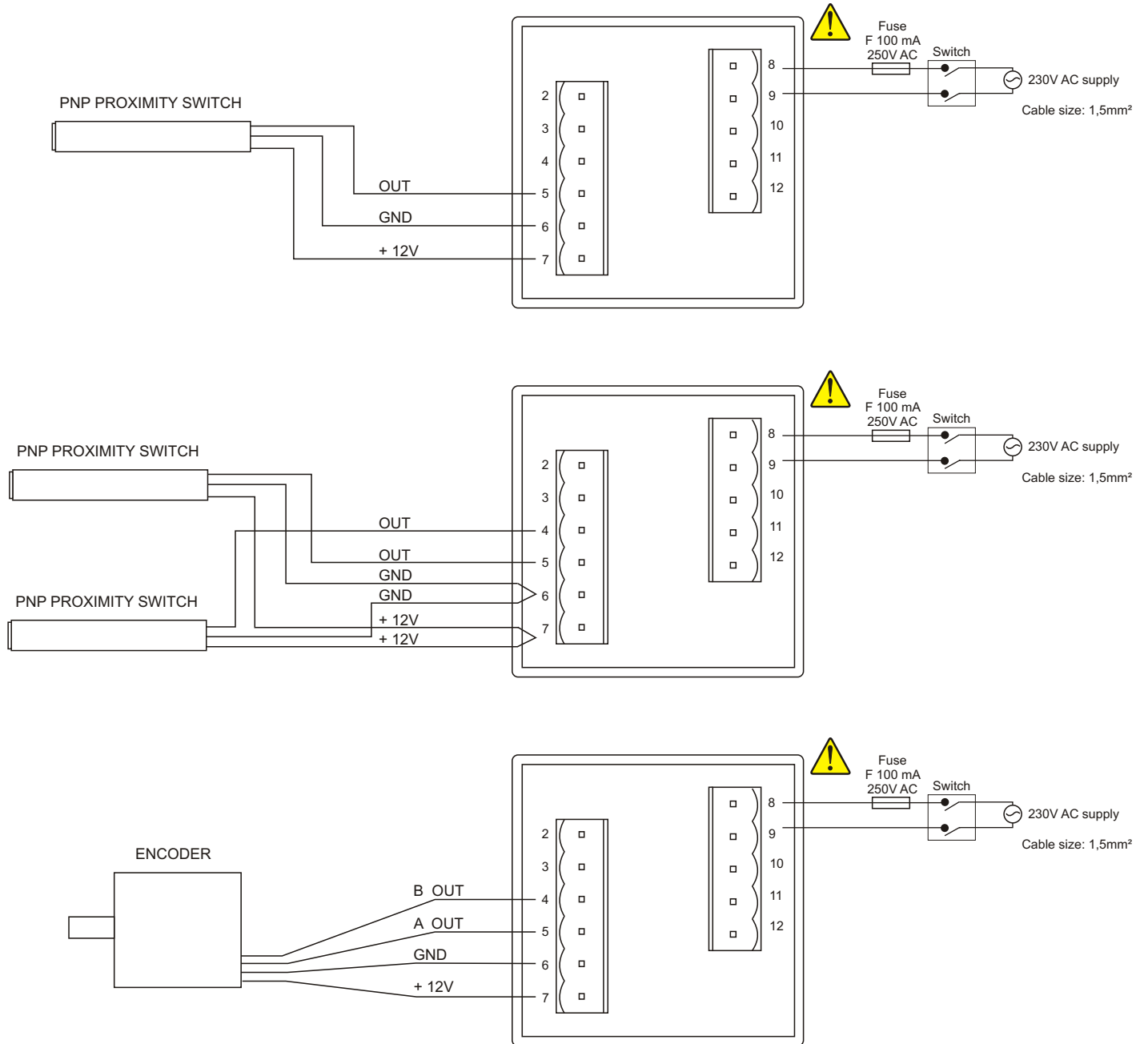

NOTE: NPN PROXIMITY SWITCH connection is the same as PNP PROXIMITY SWITCH connection.