



Read the user manual carefully before using the device! Responsibility for any damage, loss or accidents to persons arising from failure to comply with the warnings in the user manual belongs to the user. In case of malfunctions in this case, the device will be out of warranty.

ESDC8034

Digital Thermostat

- On-off cooling control,
- Four relay outputs for compressor, defrost, fan and aux,
- Three NTC probe inputs for cabin, evaporator and condenser,
- Ability to enter offset values for NTC probe inputs,
- Two digital inputs for door control and multifunctional control,
- Ability to adjust set value lower and upper limits,
- Ability to enter compressor protection parameters,
- Manual rapid cooling/heating feature,
- Ability to adjust the compressor's operation, stop or periodic operation in probe failures,
- Ability to defrost depending on time and evaporator temperature or manually,
- Ability to adjust defrost time and interval,
- Ability to adjust set value lower and upper limits,
- Ability to adjust set value lower and upper alarm limits,
- Ability to keep a maximum of 3 HACCP alarm records,
- Ability to display temperature in °F or °C,
- Communication feature with RS485 ModBus RTU protocol,
- Reading and writing all parameters with NFC,
- Audible warning feature,
- CE marked according to EN standards.



ORDER CODE: ESDC8034
ESDC-PWR (Only for control module)

Technical Specifications

Electrical Specifications

Supply Voltage	User interface: Power provided by control module Control module: 230V AC (+%10 -%20), 50/60Hz, max. 8VA
Wiring	User interface: 1.75 mm ² pluggable terminal blocks Control module: 2.5 mm ² and 1.75 mm ² pluggable terminal blocks
Cable Length	10m
Pollution Degree	2
Overvoltage Category	II
EMC-LVD	EN 61326-1:2021 - LVD: EN 61010-1: 2010

Environmental Specifications

Ambient/Storage Temperature	0 ... +50°C / -25 ... 70°C (without frosting)
Relative Humidity	Operates at humidity that decreases linearly after 31°C to 80% and drops to 50% at 40°C.
Protection Rating	User interface: According to EN 60529 standard, front panel: IP65, rear panel: IP20 Control module: According to EN 60529 standard IP00
Operational Height	Max. 2000m



KEEP AWAY device from exposed to corrosive, volatile and flammable gasses or liquids

Analog Inputs

Sensor Type	3 NTC probes (cabin, evaporator, condenser)
Measurement Range	-50,0 ... +150,0°C (-58 ... +302,0°F)
Resolution	0.1°C (1°F)
Accuracy	±1°C

Digital Inputs

Contact Type	2 dry contacts (door entry, multifunctional input)
--------------	----------------------------------------------------

Outputs

Compressor Relay Output	For resistive load: NO 250V AC 16A, For inductive load: 1/2hp 240V AC Relay life: 30,000,000 switching at no load, 100,000 switching at 250V AC 16A resistive load
Defrost Relay Output	For resistive load: NO 250V AC 8A, NC 250V AC 8A For inductive load: 1/2hp 240V AC Relay life: 30,000,000 switching at no load, 100,000 switching at 250V AC 8A resistive load
Evaporator Fan Relay Output	For resistive load: NO 250V AC 10A, For inductive load: 1/2hp 240V AC Relay life: 30,000,000 switching at no load, 100,000 switching at 250V AC 10A resistive load
AUX Relay Output	For resistive load: NO 250V AC 5A Relay life: 5,000,000 switching at no load, 100,000 switching at 250V AC 5A resistive load

Control

Control Type	On/off control of compressor, defrost, evaporator fan and aux relay with set values and digital inputs
--------------	--------------------------------------------------------------------------------------------------------

Housing

Materials	User interface: Self-extinguishing ABS Control module: Bare PCB
Dimensions	User interface: 120 x 80 x 66 mm Control module: 115 x 75 mm
Weight	570g with packaging
Mounting	User interface: Panel mounting with screws Control module: Mounts to electrical panel with plastic spacers.

 **The device should not be cleaned with solvent-containing or abrasive cleaning agents (thinner, gasoline, acid, etc.).**

Connection Diagram

Display:

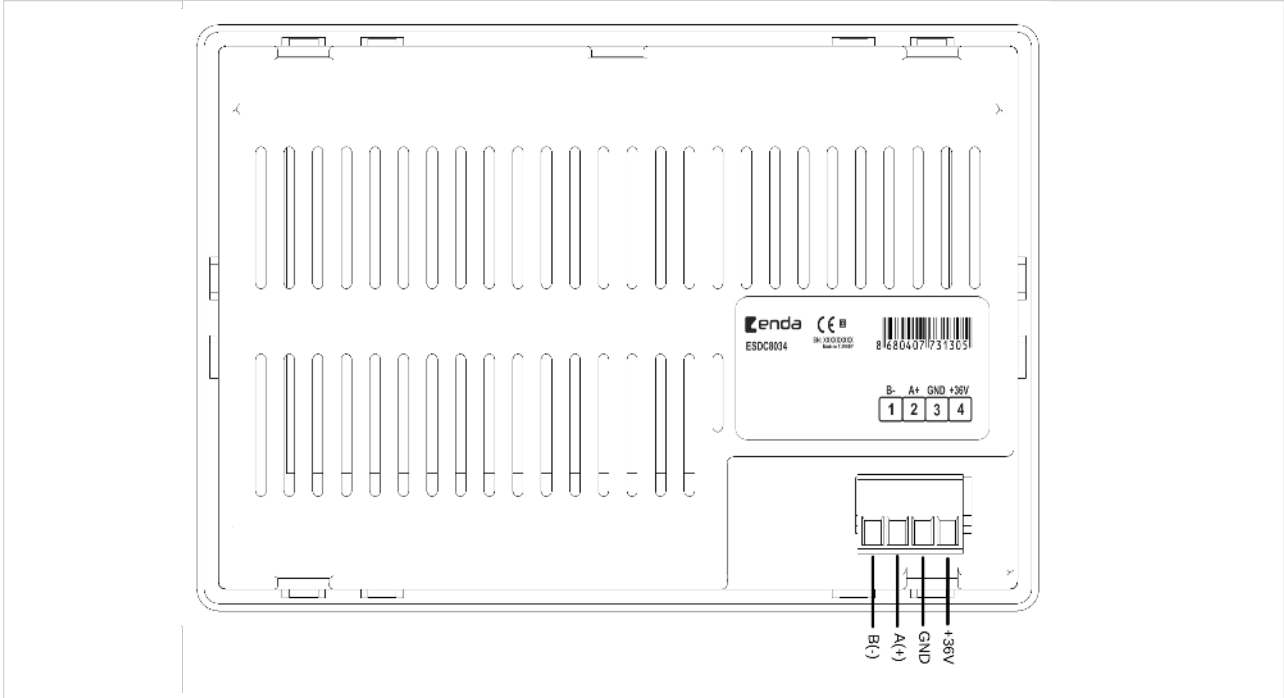

Control Module:

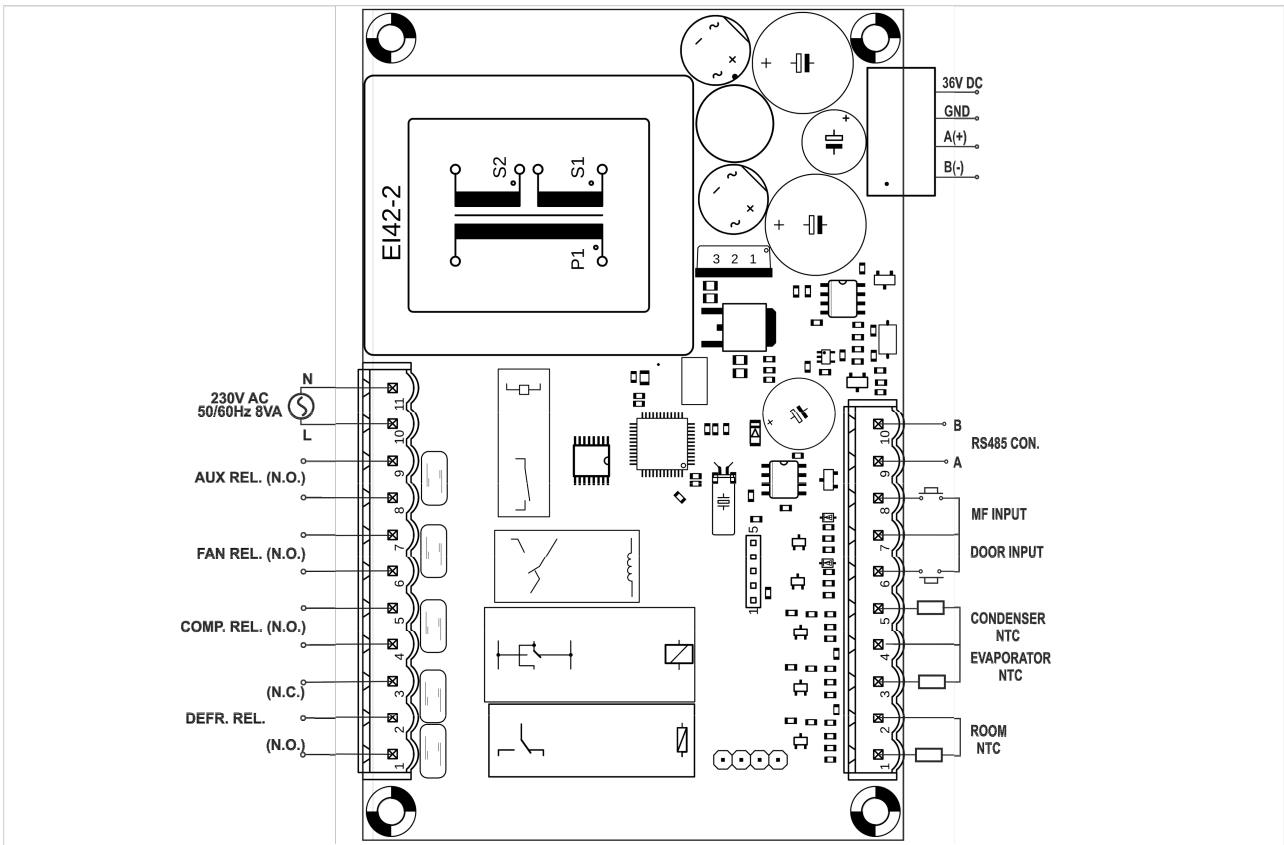

Supply Voltage:
184-253V AC
50/60Hz 8VA

Fuse F 100 mA 250V AC
Switch
230V AC Supply
Line 10
Neutral 11
Fuse should be connected.
Cable size: 1,5mm²

Note:
1) Mains supply cords shall meet the requirements of IEC 60227 or OEC 60245.
2) In accordance with the safety regulations, the power supply switch shall bring the identification of the relevant instrument and it should be easily accessible by the operator.

Equipment is protected throughout by **DOUBLE INSULATION**

Holding screw 0.4-0.5Nm.

Assembly

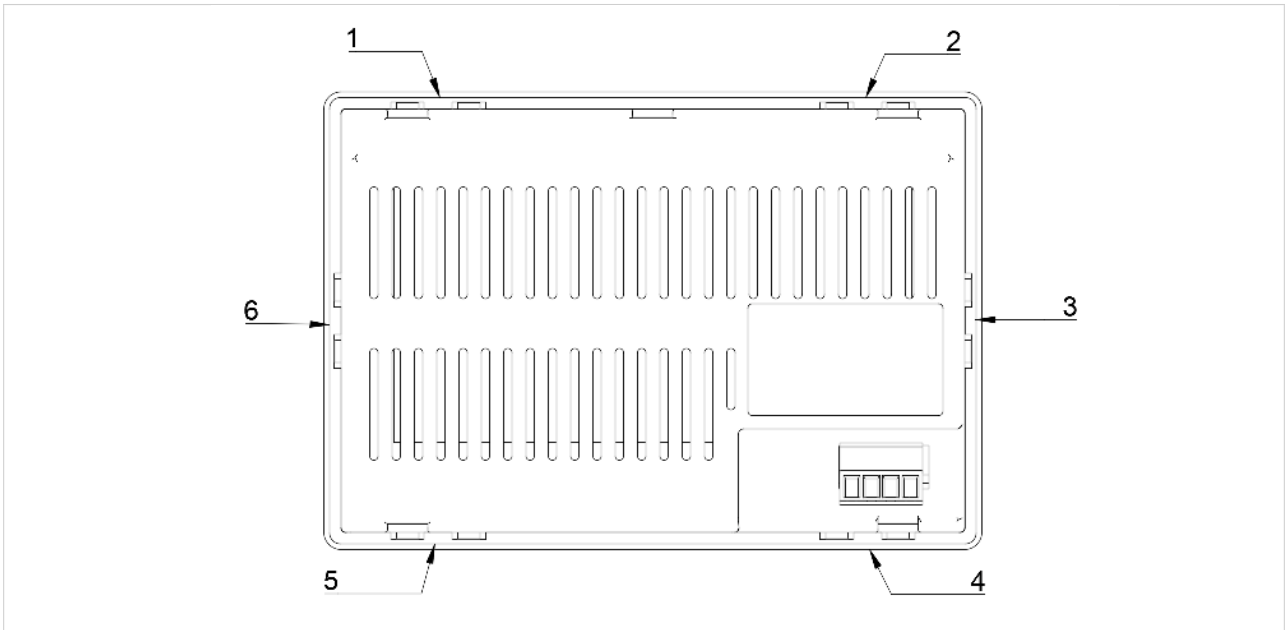

The product can be assembled/disassembled by applying pressure to the points shown above.

Dimensions

Display:

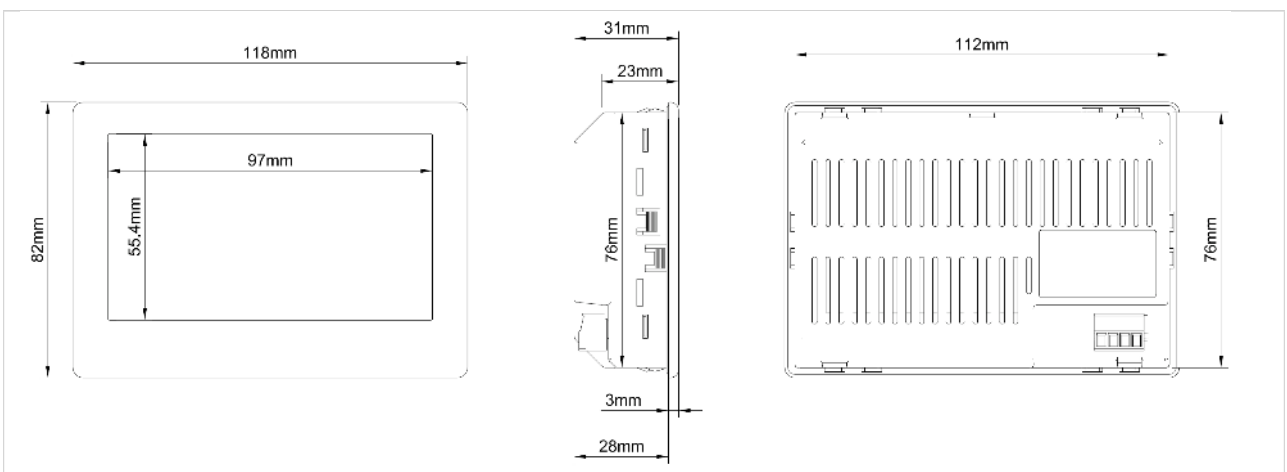

Control Module:

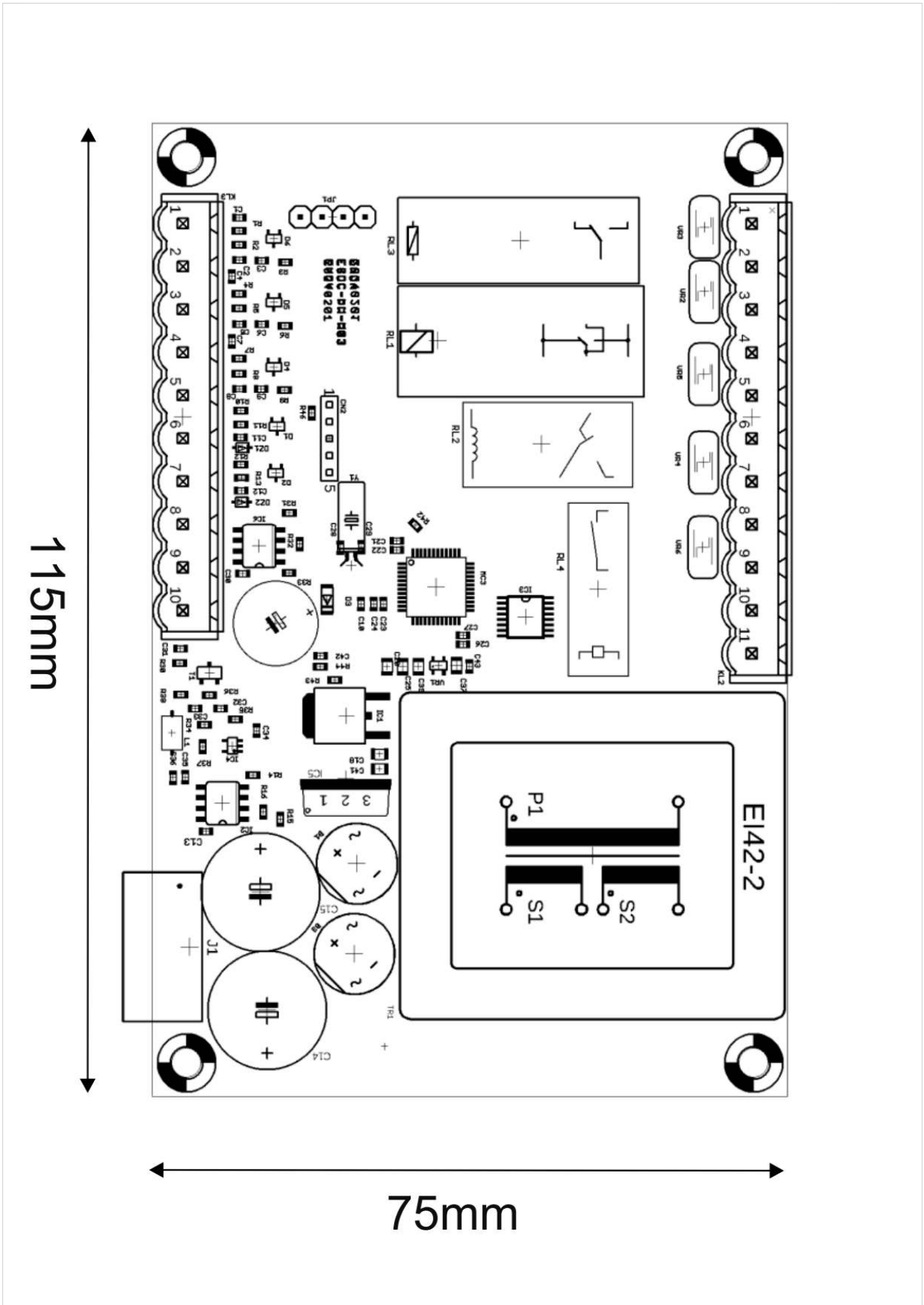

Panel Commands

Display Definition

- In working mode, the probe temperature is displayed on the upper display, and the set value of the probe temperature is displayed on the lower display.

- In the menu, the parameter name is displayed on the upper display, and the value of the selected parameter is displayed on the lower display.

When changing the set value in working mode or changing the parameter value in the menu, pressing the **SET** key causes the value of the relevant parameter to flash on the lower display.

The  keys can be used to change this value. Then, pressing the **SET** key again saves the value of that parameter.





Viewing and Changing the Set Value

 → **SET** →  →  →  →  → 

If the **SET** button is pressed in "Working mode", the set value is displayed on the lower display. The set value can be changed using the  buttons.

Viewing Evaporator and Condenser Probe Measurement Value

 →  → 

In "Working mode" (without button lock) if the **SET** and  button is pressed for 4 seconds, the menu displaying alarms and other information is accessed. From there,  and  buttons can be used to display $Pb2$ (evaporator temperature) and $Pb3$ (condenser temperature). If no button is pressed for 60 seconds or the  button is pressed, the device returns to "Working mode".

Locking and Unlocking the Keys

If no button is pressed for 60 seconds, the message $L O C$ is displayed on the screen and the buttons are locked. While the buttons are locked, pressing any button for 2 seconds displays the message $U N L$ on the screen and unlocks the buttons.

Manual Defrost Operation

In "Working mode", if the  button is pressed for 4 seconds, the defrost process is manually started or stopped.

1- $d3$ is 0, manual defrost is disabled.

2- If the measured value of the evaporator probe is greater than the value in parameter $d2$, defrost is not initiated."

Overcooling/Overheating Operation

In "Working mode", if the  button is pressed for 4 seconds,

If $r5 = 0$ and $r8 = 1$, overcooling is initiated (during $r7$ duration, $SP = SP - r6$),

If $r5 = 1$ and $r8 = 1$, overheating is initiated (during $r7$ duration $SP = SP + r6$)

Energy Saving



In "Working mode", if the  button is pressed, energy saving is started.

(for a maximum duration of $HE2$, $SP = SP + r4$ becomes.)

Activating Cabinet Light

In "Working mode", if the  button is pressed, cabinet light is activated or deactivated. (should be $u1 = 1$.)

Manual ON / OFF

In "Working mode",  button is pressed for 2 seconds, the display turns off, temperature measurement and control are halted, outputs become inactive. While the device is in this state, if the  button is pressed again for 2 seconds, the display turns on and the device continues to measure and control the temperature.

Silencing the Buzzer

The buzzer sounds if an alarm condition occurs. In "Working mode", the buzzer can be silenced by pressing the  button.(if $u9 = 1$)

Viewing Alarm Informations

In "Working mode" (without button lock) if the **SET** and ∇ button is pressed for 4 second, the menu displaying alarms and other information is accessed. From here, you can view the **id**, **Ah**, and **AL** alarms using the $\Delta\nabla$ buttons. Information related to the selected alarm will start to be displayed in sequence. If no button is pressed for 60 seconds or if the **Power** button is pressed, the device will return to working mode. The maximum duration for each alarm to remain active is 99:9 (hours).

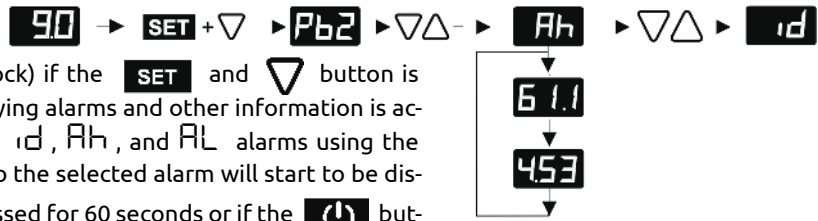

Resetting the Alarms That Occurred

In "Working mode" (without button lock) if the **SET** and ∇ button is pressed for 4 second, the menu displaying alarms and other information is accessed. From here, you can view the **id**, **Ah**, and **AL** alarms using the $\Delta\nabla$ buttons. After any of the alarms have been displayed, if you press the **SET** button while any alarm is selected, the alarms will be cleared.

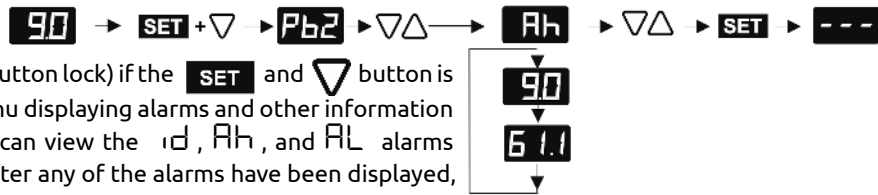

Viewing Compressor Run Time

In "Working mode" (without button lock) if the **SET** and ∇ button is pressed for 4 second, the menu displaying alarms and other information is accessed. From here, you can use the $\Delta\nabla$ buttons to select the **ch** message and view the compressor's operating time. The compressor's operating time can be stored for up to 99:9 hours.

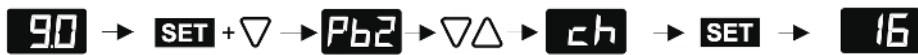

Resetting Compressor Run Time

In "Working mode" (without button lock) if the **SET** and ∇ button is pressed for 4 second, the menu displaying alarms and other information is accessed. From here, use the $\Delta\nabla$ buttons to select the **rch** message. Press and hold the **SET** button, then use the $\Delta\nabla$ buttons to set the password to "149". After pressing the **SET** button, the **---** message will be displayed, indicating that the compressor operating time has been reset. The device will then return to working mode.

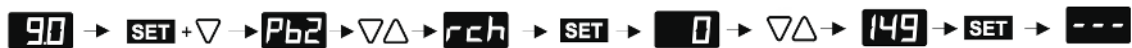

Factory Settings

In working mode, if the **SET** button is pressed for 4 seconds, the password (PA) message will be displayed. After setting the security parameter PA to "-44", and keep pressing down button for 6 seconds, the dF message will appear on the display after which the device will reset to factory settings

Viewing Revision Date





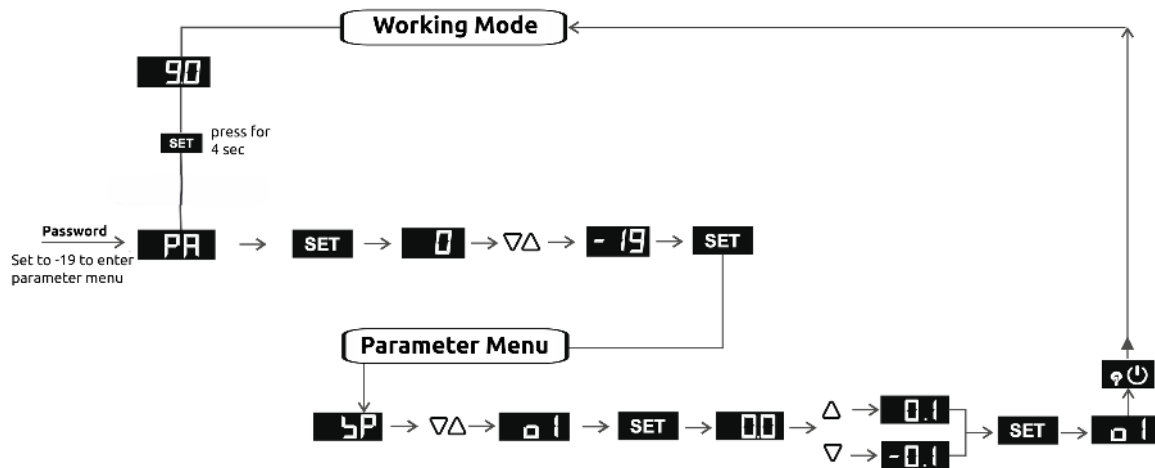







In "Working mode", if the Δ and ∇ buttons are pressed, the revision date is displayed as DD/MM/YYYY.

Changing Parameter Values

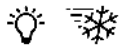
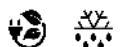

In working mode, if the **SET** button is pressed for 4 seconds, the password (PA) message will be displayed. Press the **SET** button, then use the Δ/∇ buttons to set the password to "-19" and press the **SET** button again to enter the parameter menu. In the menu, use the Δ/∇ buttons to navigate. When the desired parameter message is displayed, if the **SET** button is pressed, the parameter value will flash. Use the Δ/∇ buttons to change the parameter value. After changing the value, press the **SET** button to save it. If no button is pressed for 60 seconds or if the **Power** button is pressed, the device will return to working mode.

LEDs and Buttons

LED Definitions		Button Definitions	
	On/Off Led Does not light up when the device is on (ON), lights up when it is off (OFF).		Set Button
	Compressor Led Lights up when the compressor is running, flashes when the protection delays are active, and goes out when it is not running.	SET	- In working mode, it shows the set value, enters the parameter menu, - In programming mode, it shows the value of the selected parameter, confirms the changed parameter value.
	Defrost Led Lights up when defrost is performed, flashes when protection delays, drip-emptying time are active, and goes out when it is not running.		Up Button - In programming mode, it switches between parameters, increases the value of the selected parameter. - In working mode, it turns off the alarm sound if the audible alarm is active.
	Evaporator Fan Led Lights up when the evap fan output is active, goes out when it is not running.		Down Button In programming mode, it switches between parameters, decreases the value of the selected parameter. - In working mode, it turns off the alarm sound if the audible alarm is active.
AUX	AUX Led Lights up when the AUX output is active, goes out when it is not running.		
°C	Celsius Led Lights up for °C(Celsius).		Lighting/Rapid Cooling Button - In working mode, it turns on/off the lighting, performs rapid cooling/heating.
°F	Fahrenheit Led Lights up for °F(Fahrenheit).		
HACCP	HACCP Alarm Led Flashes when a new alarm occurs, lights up if the last alarm created by the user is checked. Goes out if all alarm conditions are checked.		Energy Saving/Manual Defrost Button - In working mode, it turns on/off the energy saving mode, performs manual defrost when held down and conditions are suitable.
	Energy Saver Led Lights up when the energy saving mode is active, goes out if it is not.		On/Off Button - Turns the device on/off.
	Service Led Lights up when the compressor operating limit time is reached.		
	Fast Heating/Cooling Led Lights up when rapid cooling/heating is performed.		
	Warning Led Lights up in alarm conditions and probe failures.		

Error - Warning - Alarm Definitions

	Definition	Outputs
P _{r1}	Cabin Probe Fault -Check the cabin probe connection. -The compressor operates according to parameters C4 and C5.	All outputs are turned off.
P _{r2}	Evaporator Probe Fault -Check the evaporator probe connection. -Check parameter P4.	The evaporator fan output is turned off.
P _{r3}	Condenser Probe Fault Check the condenser probe connection.	The condenser fan output is turned off.
AL	Low Temperature Alarm Check parameters A0, A1, and A2.	The outputs remain unchanged.
Ah	High Temperature Alarm Check parameters A4 and A5.	The outputs remain unchanged.
i _d	Door Open Alarm -Check the door digital input. -Check parameters i0 and i1.	Check the i0 parameter.
i _A	Multi-Function Input Alarm -Check the multi-function digital input. -Check parameters i5 and i6.	Check the i5 parameter.
LP	Low Pressure Alarm -Check i5 and i6 parameters.	The outputs remain unchanged.
i _{sd}	High Pressure Alarm	The outputs remain unchanged.
coh	Condenser Probe Overheating Alarm	The outputs remain unchanged.
c _{sd}	Compressor Shutdown Alarm After Condenser Probe Overheating -Check the condenser probe. -Check parameter C7.	Compressor output is turned off.
d _{Fd}	Defrost Alarm	The outputs remain unchanged.

EOU	Connection Error Message Between User Interface and Control Module	The outputs remain unchanged.
LOC	Key Lock Message -To change the keypad lock settings, see Keypad Locking and Unlocking Procedures.	The outputs remain unchanged.
UNL	Key Lock Opened Message -To change the keypad lock settings, see Keypad Locking and Unlocking Procedures.	The outputs remain unchanged.
DF	Factory Reset Message -The device starts operating according to factory settings.	The outputs remain unchanged.
SrS	Service Alarm - Check parameters S1 and S2.	All outputs are turned off.

Configuration Parameters

Display	Description	Min	Max	Unit	Default
SEt	Set value	r 1	r 2	°C/°F	4
cA 1	Cabinet probe offset value	-25	25	-	0
cA2	Evaporator probe offset value	-25	25	-	0
cA3	Auxiliary probe offset value	-25	25	-	0
P 1	Decimal point 0: No 1: Yes	0	1	-	0
P2	Temperature unit °C: Celcius °F: Fahrenheit	°C	°F	-	°C
P3	Evaporator probe function 0: Not used 1: Used for defrost and fan control 2: Used for fan control only	0	2	-	1
P4	Condenser probe use 0: Not used 1: Used	0	1	-	0

Display	Description	Min	Max	Unit	Default
P5	Value displayed 0: Cabinet temperature 1: Setpoint 2: Evaporator temperature 3: Condenser temperature	0	3	-	0
P8	Display refresh time	1	250	ds	1
r0	Setpoint differential	1	20	-	3
r1	Setpoint lower limit	-60	r2	°C/°F	-40
r2	Setpoint upper limit	r1	150	°C/°F	50
r3	Enable setpoint lock 0: Disable setpoint lock 1: Enable setpoint lock	0	1	-	0
r4	Setpoint offset in energy saving	0	99	°C/°F	0
r5	Type of control mode 0: Cold mode 1: Hot mode	0	1	-	0
r6	Setpoint offset in overcooling/overheating	0	99	°C/°F	0
r7	Duration overcooling/overheating	0	240	min	2
r8	Down key additional function 0: Disabled 1: Overcooling/overheating 2: Energy saving	0	2	-	2

Compressor Protection Parameters

Display	Description	Min	Max	Unit	Default
c0	Compressor-on delay from power-on	0	240	min	0
c2	Minimum compressor-off time	0	240	min	3
c3	Minimum compressor-on time	0	240	sec	0
c4	Compressor-off time in cabinet probe alarm	0	240	min	10
c5	Compressor-on time in cabinet probe alarm	0	240	min	10
c6	If the condenser temperature is higher than this value, the condenser temperature alarm 'COH' becomes active	0	150	°C/°F	80

Display	Description	Min	Max	Unit	Default
c7	If the condenser temperature is higher than this value, the condenser temperature alarm 'Csd' becomes active	0	150	°C/°F	90
c8	Csd alarm delay	0	15	min	1
c10	Compressor run time limit. When the compressor runs for more than this time, the maintenance led turns on	0	999	hr	0

Defrost Control Parameters

Display	Description	Min	Max	Unit	Default
d0	Automatic defrost interval	0	99	hr	8
d1	Type of defrost 0: Electric (Compressor off) defrost 1: Hot gas (compressor on) defrost 2: Compressor stopped	0	2	-	0
d2	Defrost end threshold (P3 must be 1)	-60	150	°C/°F	2
d3	Defrost duration	0	99	min	30
d4	Defrost starts with energy 0: Defrost does not start with energy 1: Defrost starts with energy	0	1	-	0
d5	Defrost delay from power-on	0	99	min	0
d6	Value displayed when defrosting 0: The cabin temperature is displayed 1: Locked display 2: During defrost, "dEF" message is displayed	0	2	-	1
d7	Dripping time	0	15	min	4
d8	Defrost interval count mode 0: The time counter (d0) between two defrosts is decremented regardless of any condition 1: The time counter (d0) between two defrosts is decremented only as long as the compressor is running 2: The time counter (d0) between two defrosts is decremented only as long as the evaporator probe temperature is less than d9 par. (P2 < d9) 3: Adaptive defrost	0	3	-	0
d9	Evaporation threshold for automatic defrost interval count (when d8=2)	-60	99	°C/°F	0

Display	Description	Min	Max	Unit	Default
d 11	Defrost alarm max. is turned off if the display time has been reached 0: The defrost alarm is not turned off 1: The defrost alarm is turned off	0	1	-	0
d 15	Compressor-on consecutive time for hot gas defrost (when d1=1)	0	99	min	0
d 16	Pre-dripping time for hot gas defrost	0	99	min	0
d 18	In defrost normal operation mode, if the sum of the times during which the evaporator temperature is below the calculated ideal evaporation temperature reaches this time, defrost is activated	0	99	min	40
d 19	Defrost is active if the evaporator probe temperature (calculated evap temperature-d19) is lower than this value	0	150	°C/°F	3
d22	Adaptive defrost evap probe termination temperature	- 10	10	°C/°F	-2

Alarm Control Parameters

Display	Description	Min	Max	Unit	Default
A0	Select value for high/low temperature alarms 0: Cabinet probe 1: Evaporator probe	0	1	-	0
A 1	Low temperature alarm threshold	-60	A4	°C/°F	-50
A2	Type of low temperature alarm 0: Disabled 1: The alarm activation value becomes SP- A1 2: The alarm activation value becomes A1	0	2	-	2
A4	High temperature alarm threshold	A 1	99	°C/°F	60
A5	Type of high temperature alarm 0: Disabled 1: Alarm activation value becomes SP+A4 2: The alarm activation value becomes A4	0	2	-	2
A6	High temperature alarm delay from power-on	0	240	min	120
A7	High/low temperature alarm delay	0	240	min	15
A8	High temperature alarm delay post-defrosting	0	240	min	15
A9	High temperature alarm delay from door closure	0	240	min	15
A 11	High/low temperature alarm reset differential	1	15	-	2

Display	Description	Min	Max	Unit	Default
51	Service alarm set value	-60	150	°C/°F	65
52	Service alarm stop value	-60	150	°C/°F	50

Fan Control Parameters

Display	Description	Min	Max	Unit	Default
F0	Evaporator fan mode in normal function 0: Off 1: On 2: On if compressor on 3: Thermoregulated(with room temperature + F1) 4: Thermoregulated(with room temperature + F1) if compressor on 5: Function of F6 6: Thermoregulated(with F1) 7: Thermoregulated(with F1) if compressor on	0	7	-	1
F1	Evaporator fan regulation threshold	-60	150	°C/°F	-4
F2	Evaporator fan mode in defrost and drip mode 0: Off 1: On 2: Dependent function of F0	0	2	-	0
F3	Post-dripping delay of the evap. fan	0	15	min	2
F4	Time evaporator fan off in energy saving	0	240	sec	30
F5	Time evaporator fan on in energy saving	0	240	sec	30
F6	Function for high/low humidity 0: For low humidity (with F17 and F18 if compressor off, on if compressor on) 1: For high humidity(on)	0	1	-	0
F7	Evaporator fans on threshold from dripping (relative to setpoint)	-60	99	°C/°F	5
F8	Evaporator fan regulation threshold differential	1	20	-	2
F9	Evaporator fan off delay from compressor off(if F0 = 2 or 5)	0	240	sec	10
F11	Condenser fan on threshold according to condenser probe	0	99	°C/°F	15
F12	Condenser fan off delay from compressor off	0	240	sec	30
F17	Time evaporator fan off in low humidity	0	240	sec	60
F18	Time evaporator fan on in low humidity	0	240	sec	10

Digital Input Parameters

Display	Description	Min	Max	Unit	Default
i0	Door switch input functions 0: Disabled 1: Compressor and evap. fan off 2: Evap. fan off 3: Cabinet light on 4: Compressor and evap. fan off, cabinet light on 5: Evap. fan off, cabinet light on	0	5	-	5
i1	Door digital input activation 0: N.O. 1: N.C.	0	1	-	0
i2	Door open alarm delay	0	120	min	30
i3	Max. time for inhibiting regulation with door open (If 0 is selected, the effect continues until the door closes.)	0	120	min	15
i4	Door digital input alarm storage 0: Passive 1: Active	0	1	-	0
i5	Multi-purpose input function 0: Disabled 1: Energy saving 2: Alarm iA 3: Alarm iSd 4: Enable aux output 5: Switches device on/off 6: Alarm LP	0	6	-	0
i6	Multifunction digital input activation 0: N.O. 1: N.C.	0	1	-	0
i7	Multi-purpose input alarm delay	0	120	min	0
i8	Number of multi-purpose input activations for high pressure alarm (if i5 = 3)	0	15	-	0
i9	Counter reset time for high pressure alarm	1	999	min	240
i10	Door closed consecutive time for energy saving	0	999	min	0

AUX Output Parameters

Display	Description	Min	Max	Unit	Default
u1	Aux relay control 0: As a lighting output (i0 and u2 must be controlled) 1: As a demister output (must check u6 par) 2: As AUX output (u2 must be checked) 3: As alarm output (u4 must be checked) 4: As evaporator output (u7 and u8 should be checked) 5: As the condenser fan output according to the condenser temperature (P4, F11, F12 should be checked)	0	5	-	0
u2	Activating the lighting and AUX outputs on and off when the device is manually off/on 0: Passive 1: Active	0	1	-	0
u4	Enable silencing alarm output 0: Passive 1: Active	0	1	-	1
u6	Duration demisting on	1	120	min	5
u7	In order for the evaporator output to be active, the cabin temperature must be above this adjusted parameter	0	99	°C/°F	2
u8	Evaporatör output activation 0: N.O. 1: N.C.	0	1	-	0
u9	Enable alarm buzzer 0: Passive 1: Active	0	1	-	0

Modbus Communication Parameters

Display	Description	Min	Max	Unit	Default
h1	Modbus slave device address	1	247	-	1

Display	Description	Min	Max	Unit	Default
h2	Baud rate 0: OFF 1: 1200 bps 2: 2400 bps 3: 4800 bps 4: 9600 bps 5: 19200 bps 6: 38400 bps 7: 56000 bps 8: 57600 bps 9: 115200 bps	0	9	bps	4

Energy Saving Parameters

Display	Description	Min	Max	Unit	Default
hE2	Maximum duration energy saving (if it's 0 then it is until door opened)	0	999	min	2

ESDC8034 Digital Thermostat Modbus Map

Holding Registers

Register Addresses		Data Type	Description	Display	Permission
Decimal	Hex				
0	0x0000	word	Set value [°C/°F]	SEt	Readable Writable
1	0x0001	word	Cabinet probe offset value	cA1	Readable Writable
2	0x0002	word	Evaporator probe offset value	cA2	Readable Writable
3	0x0003	word	Auxiliary probe offset value	cA3	Readable Writable
4	0x0004	word	Evaporator probe function 0: Not used 1: Used for defrost and fan control 2: Used for fan control only	P3	Readable Writable
5	0x0005	word	Value displayed 0: Cabinet temperature 1: Setpoint 2: Evaporator temperature 3: Condenser temperature	PS	Readable Writable
6	0x0006	word	Display refresh time [ds]	P8	Readable Writable
7	0x0007	word	Setpoint differential	r0	Readable Writable
8	0x0008	word	Setpoint lower limit [°C/°F]	r1	Readable Writable
9	0x0009	word	Setpoint upper limit [°C/°F]	r2	Readable Writable
10	0x000A	word	Setpoint offset in energy saving [°C/°F]	r4	Readable Writable
11	0x000B	word	Setpoint offset in overcooling/overheating [°C/°F]	r6	Readable Writable
12	0x000C	word	Duration overcooling/overheating [min]	r7	Readable Writable
13	0x000D	word	Down key additional function 0: Disabled 1: Overcooling/overheating 2: Energy saving	r8	Readable Writable
14	0x000E	word	Compressor-on delay from power-on [min]	c0	Readable Writable

Register Addresses		Data Type	Description	Display	Permission
Decimal	Hex				
15	0x000F	word	Minimum compressor-off time [min]	c2	Readable Writable
16	0x0010	word	Minimum compressor-on time [sec]	c3	Readable Writable
17	0x0011	word	Compressor-off time in cabinet probe alarm [min]	c4	Readable Writable
18	0x0012	word	Compressor-on time in cabinet probe alarm [min]	c5	Readable Writable
19	0x0013	word	If the condenser temperature is higher than this value, the condenser temperature alarm 'COH' becomes active [°C/°F]	c6	Readable Writable
20	0x0014	word	If the condenser temperature is higher than this value, the condenser temperature alarm 'Csd' becomes active [°C/°F]	c7	Readable Writable
21	0x0015	word	CSd alarm delay [min]	c8	Readable Writable
22	0x0016	word	Compressor run time limit. When the compressor runs for more than this time, the maintenance led turns on [hr]	c10	Readable Writable
23	0x0017	word	Automatic defrost interval [hr]	d0	Readable Writable
24	0x0018	word	Type of defrost 0: Electric (Compressor off) defrost 1: Hot gas (compressor on) defrost 2: Compressor stopped	d1	Readable Writable
25	0x0019	word	Defrost end threshold (P3 must be 1) [°C/°F]	d2	Readable Writable
26	0x001A	word	Defrost duration [min]	d3	Readable Writable
27	0x001B	word	Defrost delay from power-on [min]	d5	Readable Writable
28	0x001C	word	Value displayed when defrosting 0: The cabin temperature is displayed 1: Locked display 2: During defrost, "DEF" message is displayed	d6	Readable Writable
29	0x001D	word	Dripping time [min]	d7	Readable Writable

Register Addresses		Data Type	Description	Display	Permission
Decimal	Hex				
30	0x001E	word	Defrost interval count mode 0: The time counter (d0) between two defrosts is decremented regardless of any condition 1: The time counter (d0) between two defrosts is decremented only as long as the compressor is running 2: The time counter (d0) between two defrosts is decremented only as long as the evaporator probe temperature is less than d9 par. (P2 < d9) 3: Adaptive defrost	d8	Readable Writable
31	0x001F	word	Evaporation threshold for automatic defrost interval count (when d8=2) [°C/°F]	d9	Readable Writable
32	0x0020	word	Compressor-on consecutive time for hot gas defrost (when d1=1) [min]	d15	Readable Writable
33	0x0021	word	Pre-dripping time for hot gas defrost [min]	d16	Readable Writable
34	0x0022	word	In defrost normal operation mode, if the sum of the times during which the evaporator temperature is below the calculated ideal evaporation temperature reaches this time, defrost is activated [min]	d18	Readable Writable
35	0x0023	word	Defrost is active if the evaporator probe temperature (calculated evap temperature-d19) is lower than this value [°C/°F]	d19	Readable Writable
36	0x0024	word	Adaptive defrost evap probe termination temperature [°C/°F]	d22	Readable Writable
37	0x0025	word	Low temperature alarm threshold [°C/°F]	A1	Readable Writable
38	0x0026	word	Type of low temperature alarm 0: Disabled 1: The alarm activation value becomes SP- A1 2: The alarm activation value becomes A1	A2	Readable Writable
39	0x0027	word	High temperature alarm threshold [°C/°F]	A4	Readable Writable
40	0x0028	word	Type of high temperature alarm 0: Disabled 1: Alarm activation value becomes SP+A4 2: The alarm activation value becomes A4	A5	Readable Writable
41	0x0029	word	High temperature alarm delay from power-on [min]	A6	Readable Writable
42	0x002A	word	High/low temperature alarm delay [min]	A7	Readable Writable

Register Addresses		Data Type	Description	Display	Permission
Decimal	Hex				
43	0x002B	word	High temperature alarm delay post-defrosting [min]	A8	Readable Writable
44	0x002C	word	High temperature alarm delay from door closure [min]	A9	Readable Writable
45	0x002D	word	High/low temperature alarm reset differential	A11	Readable Writable
46	0x002E	word	Service alarm set value [°C/°F]	51	Readable Writable
47	0x002F	word	Service alarm stop value [°C/°F]	52	Readable Writable
48	0x0030	word	Evaporator fan mode in normal function 0: Off 1: On 2: On if compressor on 3: Thermoregulated(with room temperature + F1) 4: Thermoregulated(with room temperature + F1) if compressor on 5: Function of F6 6: Thermoregulated(with F1) 7: Thermoregulated(with F1) if compressor on	F0	Readable Writable
49	0x0031	word	Evaporator fan regulation threshold [°C/°F]	F1	Readable Writable
50	0x0032	word	Evaporator fan mode in defrost and drip mode 0: Off 1: On 2: Dependent function of F0	F2	Readable Writable
51	0x0033	word	Post-dripping delay of the evap. fan [min]	F3	Readable Writable
52	0x0034	word	Time evaporator fan off in energy saving [sec]	F4	Readable Writable
53	0x0035	word	Time evaporator fan on in energy saving [sec]	F5	Readable Writable
54	0x0036	word	Function for high/low humidity 0: For low humidity (with F17 and F18 if compressor off, on if compressor on) 1: For high humidity(on)	F6	Readable Writable
55	0x0037	word	Evaporator fans on threshold from dripping (relative to setpoint) [°C/°F]	F7	Readable Writable
56	0x0038	word	Evaporator fan regulation threshold differential	F8	Readable Writable

Register Addresses		Data Type	Description	Display	Permission
Decimal	Hex				
57	0x0039	word	Evaporator fan off delay from compressor off(if F0 = 2 or 5) [sec]	F9	Readable Writable
58	0x003A	word	Condenser fan on threshold according to condenser probe [°C/°F]	F 11	Readable Writable
59	0x003B	word	Condenser fan off delay from compressor off [sec]	F 12	Readable Writable
60	0x003C	word	Time evaporator fan off in low humidity [sec]	F 17	Readable Writable
61	0x003D	word	Time evaporator fan on in low humidity [sec]	F 18	Readable Writable
62	0x003E	word	Door switch input functions 0: Disabled 1: Compressor and evap. fan off 2: Evap. fan off 3: Cabinet light on 4: Compressor and evap. fan off, cabinet light on 5: Evap. fan off, cabinet light on	i0	Readable Writable
63	0x003F	word	Door open alarm delay [min]	i2	Readable Writable
64	0x0040	word	Max. time for inhibiting regulation with door open (If 0 is selected, the effect continues until the door closes.) [min]	i3	Readable Writable
65	0x0041	word	Multi-purpose input function 0: Disabled 1: Energy saving 2: Alarm iA 3: Alarm iSd 4: Enable aux output 5: Switches device on/off 6: Alarm LP	i5	Readable Writable
66	0x0042	word	Multi-purpose input alarm delay [min]	i7	Readable Writable
67	0x0043	word	Number of multi-purpose input activations for high pressure alarm (if i5 = 3)	i8	Readable Writable
68	0x0044	word	Counter reset time for high pressure alarm [min]	i9	Readable Writable
69	0x0045	word	Door closed consecutive time for energy saving [min]	i 10	Readable Writable

Register Addresses		Data Type	Description	Display	Permission
Decimal	Hex				
70	0x0046	word	Aux relay control 0: As a lighting output (i0 and u2 must be controlled) 1: As a demister output (must check u6 par) 2: As AUX output (u2 must be checked) 3: As alarm output (u4 must be checked) 4: As evaporator output (u7 and u8 should be checked) 5: As the condenser fan output according to the condenser temperature (P4, F11, F12 should be checked)	u1	Readable Writable
71	0x0047	word	Duration demisting on [min]	u6	Readable Writable
72	0x0048	word	In order for the evaporator output to be active, the cabin temperature must be above this adjusted parameter [°C/°F]	u7	Readable Writable
73	0x0049	word	Maximum duration energy saving (if it's 0 then it is until door opened) [min]	hE2	Readable Writable
74	0x004A	word	Modbus slave device address	h1	Readable Writable
75	0x004B	word	Baud rate [bps] 0: OFF 1: 1200 bps 2: 2400 bps 3: 4800 bps 4: 9600 bps 5: 19200 bps 6: 38400 bps 7: 57600 bps 8: 115200 bps	h2	Readable Writable

Coils

Register Addresses		Data Type	Description	Display	Permission
Decimal	Hex				
0	0x0000	bit	Decimal point 0: No 1: Yes	P1	Readable Writable
1	0x0001	bit	Temperature unit 0: Celcius 1: Fahrenheit	P2	Readable Writable
2	0x0002	bit	Condenser probe use 0: Not used 1: Used	P4	Readable Writable

Register Addresses		Data Type	Description	Display	Permission
Decimal	Hex				
3	0x0003	bit	Enable setpoint lock 0: Disable setpoint lock 1: Enable setpoint lock	r3	Readable Writable
4	0x0004	bit	Type of control mode 0: Cold mode 1: Hot mode	r5	Readable Writable
5	0x0005	bit	Defrost starts with energy 0: Defrost does not start with energy 1: Defrost starts with energy	d4	Readable Writable
6	0x0006	bit	Defrost alarm max. is turned off if the display time has been reached 0: The defrost alarm is not turned off 1: The defrost alarm is turned off	d11	Readable Writable
7	0x0007	bit	Select value for high/low temperature alarms 0: Cabinet probe 1: Evaporator probe	R0	Readable Writable
8	0x0008	bit	Door digital input activation 0: N.O. 1: N.C.	r1	Readable Writable
9	0x0009	bit	Door digital input alarm storage 0: Passive 1: Active	r4	Readable Writable
10	0x000A	bit	Multifunction digital input activation 0: N.O. 1: N.C.	r6	Readable Writable
11	0x000B	bit	Activating the lighting and AUX outputs on and off when the device is manually off/on 0: Passive 1: Active	u2	Readable Writable
12	0x000C	bit	Enable silencing alarm output 0: Passive 1: Active	u4	Readable Writable
13	0x000D	bit	Evaporator output activation 0: N.O. 1: N.C.	u8	Readable Writable
14	0x000E	bit	Enable alarm buzzer 0: Passive 1: Active	u9	Readable Writable

Register Addresses		Data Type	Description	Display	Permission
Decimal	Hex				
15	0x000F	bit	Fast cooling 0: Overcooling passive 1: Overcooling active		Readable Writable
16	0x0010	bit	Starting/stopping manual defrost 0: Manual defrost passive 1: Manual defrost active		Readable Writable
17	0x0011	bit	Device manual switch on/off 0: Device is on 1: Device is off		Readable Writable
18	0x0012	bit	Loading default parameters 0: Passive 1: Active		Readable Writable
19	0x0013	bit	Clearing generated HACCP alarms 0: Passive 1: Active		Readable Writable
20	0x0014	bit	Compressor runtime reset 0: Passive 1: Active		Readable Writable
21	0x0015	bit	Aux relay control 0: Passive 1: Active		Readable Writable
22	0x0016	bit	Alarm silence control 0: Passive 1: Active		Readable Writable
23	0x0017	bit	Key lock control 0: Passive 1: Active		Readable Writable
24	0x0018	bit	Defrost alarm silence control 0: Passive 1: Active		Readable Writable
25	0x0019	bit	HACCP new alarm control 0: Passive 1: Active		Readable Writable
26	0x001A	bit	Energy saving mode 0: Energy saving passive 1: Energy saving active		Readable Writable

Register Addresses		Data Type	Description	Display	Permission
Decimal	Hex				
27	0x001B	bit	Fast heating 0: Overheating passive 1: Overheating active		Readable Writable
28	0x001C	bit	Relay output test 0: Relay outputs passive 1: Relay outputs active		Readable Writable

Input Registers

Register Addresses		Data Type	Description	Display	Permission
Decimal	Hex				
0	0x0000	word	Measured cabinet temperature value [°C / °F]		Readable
1	0x0001	word	Measured evaporator probe temperature value [°C / °F]		Readable
2	0x0002	word	Measured condenser probe temperature value [°C / °F]		Readable
3	0x0003	word	Cabinet probe error status		Readable
4	0x0004	word	Evap. probe error status		Readable
5	0x0005	word	Condenser probe error status		Readable
6	0x0006	word	HACCP AH alarm temperature value [°C / °F]		Readable
7	0x0007	word	HACCP AL alarm temperature value [°C / °F]		Readable
8	0x0008	word	Duration of HACCP AH alarm [min]		Readable
9	0x0009	word	Duration of HACCP AL alarm [min]		Readable
10	0x000A	word	Duration of HACCP ID alarm [min]		Readable
11	0x000B	word	Condenser probe overheat alarm		Readable
12	0x000C	word	Compressor shutdown alarm after condenser probe warms up		Readable
13	0x000D	word	HACCP Alarm status		Readable
14	0x000E	word	Service alarm status		Readable
15	0x000F	word	Alarm status		Readable
16	0x0010	word	Compressor running time [min]		Readable
17	0x0011	word	Compressor running time [hour]		Readable
18	0x0012	word	Compressor status information		Readable
19	0x0013	word	Defrost status information		Readable
20	0x0014	word	Fan status information		Readable

Register Addresses		Data Type	Description	Display	Permission
Decimal	Hex				
21	0x0015	word	AUX status information		Readable
22	0x0016	word	Digital input status information		Readable
23	0x0017	word	Multifunction input status information		Readable

Discrete Inputs

Register Addresses		Data Type	Description	Display	Permission
Decimal	Hex				
0	0x0000	bit	Control output status (0 = OFF, 1 = ON)		Readable
1	0x0001	bit	Defrost output status (0 = OFF, 1 = ON)		Readable
2	0x0002	bit	Fan output status (0 = OFF, 1 = ON)		Readable
3	0x0003	bit	Aux output status (0 = OFF, 1 = ON)		Readable
4	0x0004	bit	Compressor run time limit control (1 = Run limit exceeded)		Readable
5	0x0005	bit	dFd alarm status (0 = OFF, 1 = ON)		Readable
6	0x0006	bit	Message before melting		Readable
7	0x0007	bit	Door digital input active status (0 = OFF, 1 = ON)		Readable
8	0x0008	bit	Multi-function digital input active status (0 = OFF, 1 = ON)		Readable
9	0x0009	bit	Cabinet probe failure (0 = No error, 1 = Error present) (All outputs are disabled)	Pr1	Readable
10	0x000A	bit	Evaporator probe failure (0 = No error, 1 = Error present) (Defrost output is disabled)	Pr2	Readable
11	0x000B	bit	Condenser probe failure (0 = No error, 1 = Error present) (Condenser fan output is disabled)	Pr3	Readable
12	0x000C	bit	Low temperature alarm (0 = No alarm, 1 = Alarm present)	AL	Readable
13	0x000D	bit	High temperature alarm (0 = No alarm, 1 = Alarm present)	Ah	Readable
14	0x000E	bit	Door open alarm (0 = No alarm, 1 = Alarm present)	id	Readable
15	0x000F	bit	Multi-function digital input alarm (0 = No alarm, 1 = Alarm present)	iA	Readable
16	0x0010	bit	Low pressure alarm (0 = No alarm, 1 = Alarm present)	LP	Readable
17	0x0011	bit	High pressure alarm (0 = No alarm, 1 = Alarm present)	hP	Readable

Register Addresses		Data Type	Description	Display	Permission
Decimal	Hex				
18	0x0012	bit	Condenser probe overheat alarm (0 = No alarm, 1 = Alarm present)	c0h	Readable
19	0x0013	bit	Compressor shutdown after condenser overheat alarm (0 = No alarm, 1 = Alarm present)	c1d	Readable
20	0x0014	bit	Service alarm (0 = No alarm, 1 = Alarm present) (All outputs are disabled)	55	Readable

NFC

EndaLink, is a mobile application that provides fast and secure data sharing between NFC supported ENDA devices and mobile devices.

 **To communicate with an NFC supported ENDA device, your mobile device must have NFC support.**

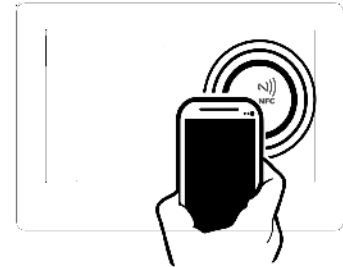

You can scan the QR codes below to access our EndaLink application on Google Play and the App Store.



enda
link

Resetting the NFC Password via EndaLink

Password reset can be done in the first 20 seconds after the power on. When the NFC password reset command is sent via EndaLink, the display on the device first displays NFC message. If the NFC password reset is successful, the buzzer will make a sound 3 times. If the reset operation fails, no sound will be produced.