



Read the user manual carefully before using the device! Responsibility for any damage, loss or accidents to persons arising from failure to comply with the warnings in the user manual belongs to the user. In case of malfunctions in this case, the device will be out of warranty.

ESDC4334

Split Digital Thermostat

- On-off cooling control,
- 4.3 inch touch screen,
- 4 relay outputs for compressor, defrost, fan, and aux,
- 3 NTC probe inputs for cabinet, evaporator, condenser,
- Ability to enter offset values for probe inputs,
- 2 digital inputs for door control and multifunction use,
- Ability to adjust lower and upper limits of the set value,
- Compressor protection parameters,
- Ability to adjust the operation, stopping, or periodic operation of the compressor in case of probe failures,
- Manual rapid cooling/heating feature,
- Time and evaporator temperature-dependent or manual defrost feature,
- Ability to adjust defrost duration and interval,
- Adjustable lower and upper alarm limits,
- Ability to keep maximum of 3 HACCP alarm records,
- Temperature display in °C or °F feature,
- RS485 Modbus RTU communication feature,
- CE marked according to EN standards.



ORDER CODE: ESDC4334
ESDC-PWR (Only for control module)

Technical Specifications

Electrical Specifications

Supply Voltage	User interface: Powered by the control module Control module: 230V AC (+%10 -%20), 50/60Hz, max. 8VA
Connection Method	User interface: Plug-in screw terminal blocks for wires up to 1.75 mm ² Control module: Fixed screw terminal blocks for up to 2.5mm ² and 1.75 mm ²
Connection Cable Length	10m
Pollution Degree	2
Overvoltage Category	II
EMC-LVD	EN 61326-1:2021 - LVD: EN 61010-1: 2010

Environmental Specifications

Ambient/Storage Temperature	0 ...+50°C / -25 ...70°C (without frost)
Relative Humidity	Up to 80% humidity at 31°C, linearly decreasing to 50% at 40°C.
Protection Class	User interface: Front panel: IP65, Rear panel: IP20 according to EN 60529 Control module: IP00 According to EN 60529
Height	Max. 2000m



It should be used in environments where flammable and corrosive gases are not present.

Analog Inputs

Sensor Type	3 NTC probes (cabinet, evaporator, condenser)
Measurement Range	-50.0 ...+150.0°C (-58 ...+302°F)
Resolution	0.1°C (1°F)
Accuracy	±1°C

Digital Inputs

Contact Type	2 dry contacts (door input, multifunctional input)
--------------	--

Outputs

Compressor Relay Output	For resistive load: NO 250V AC 16A, for inductive load: 1/2hp 240V AC Relay life: Without load 30.000.000 switching, 250V AC 16A for resistive load 100.000 switching
Defrost Relay Output	For resistive load: NO 250V AC 8A, NC 250V AC 8A For inductive load: 1/2hp 240V AC Relay life: Without load 30.000.000 switching, 250V AC 8A for resistive load 100.000 switching
Evaporator Fan Relay Output	For resistive load: NO 250V AC 10A Relay life: Without load 30.000.000 switching, 250V AC 10A for resistive load 100.000 switching
AUX Relay Output	For resistive load: NO 250V AC 5A Relay life: Without load 5.000.000 switching, 250V AC 5A for resistive load 100.000 switching

Control

Control Type	Control of compressor, evaporator fan, defrost and auxiliary output (AUX) with set values and digital inputs
--------------	--

Box

Material	User interface: Self-extinguishing plastics Control module: Open frame board
Dimensions	User interface: User Interface: 118 x 82 x 31 mm Control module: 115 x 75 mm
Weight	Approx. 540g (after packing)



The device should not be wiped with cleaning substances containing solvents (such as thinner, gasoline, acid, etc.) or abrasive cleaning agents.

Connection Diagram



ESDC4334 is a panel type defrost control device. The device must be used in accordance with the instructions. Installation and electrical connections must be carried out by technical personnel in accordance with the instructions in the user manual. During installation, care must be taken to ensure that there is no electricity. The device must be protected from humidity, vibration, and pollution. Operating temperature should be observed. Installation cables should not pass near high-power lines or other devices.

User Interface

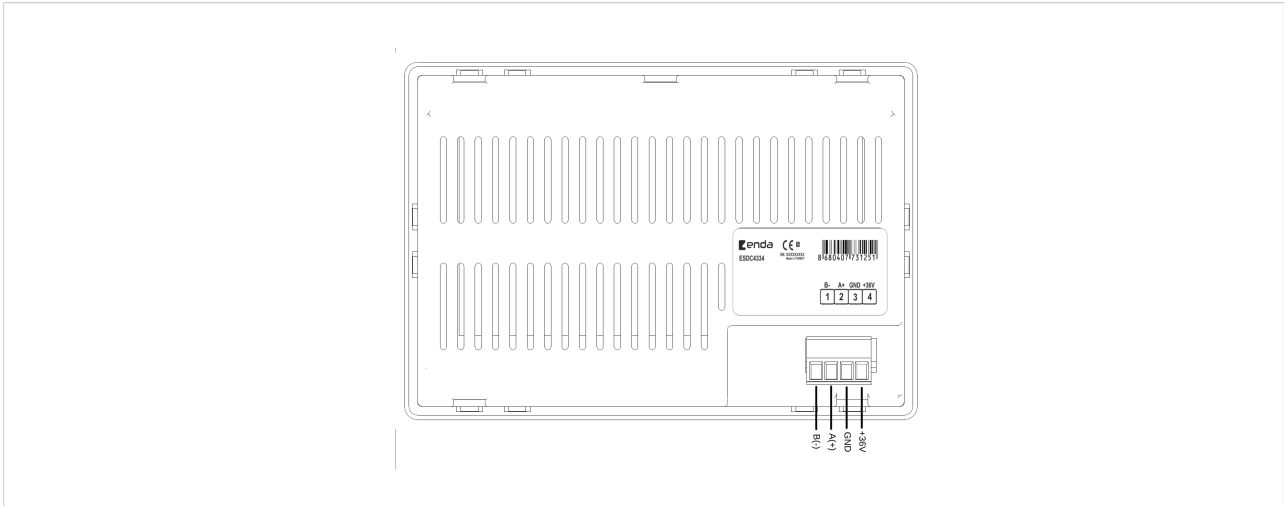

Control Module

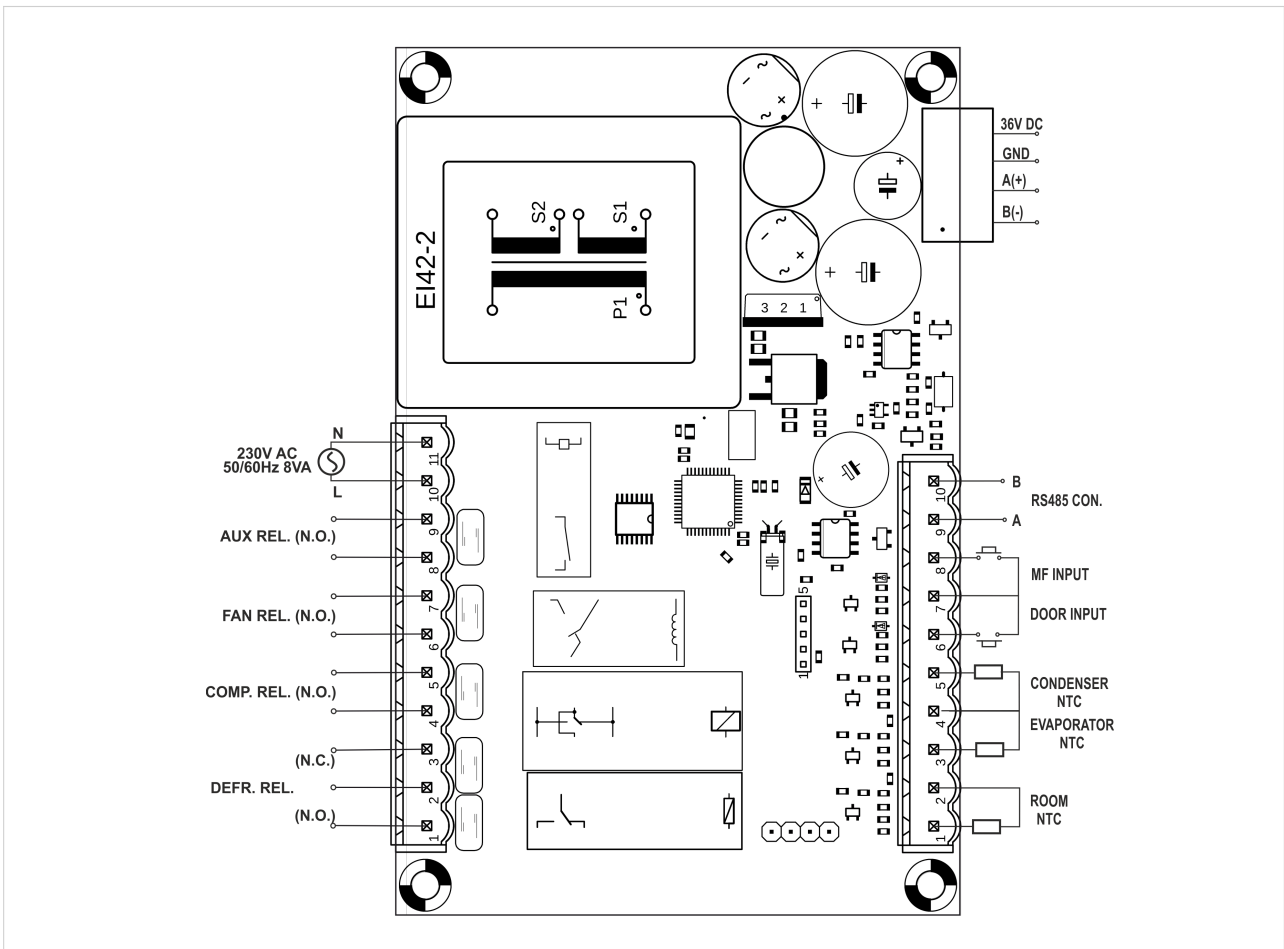

Dimensions and Assembly

User Interface:

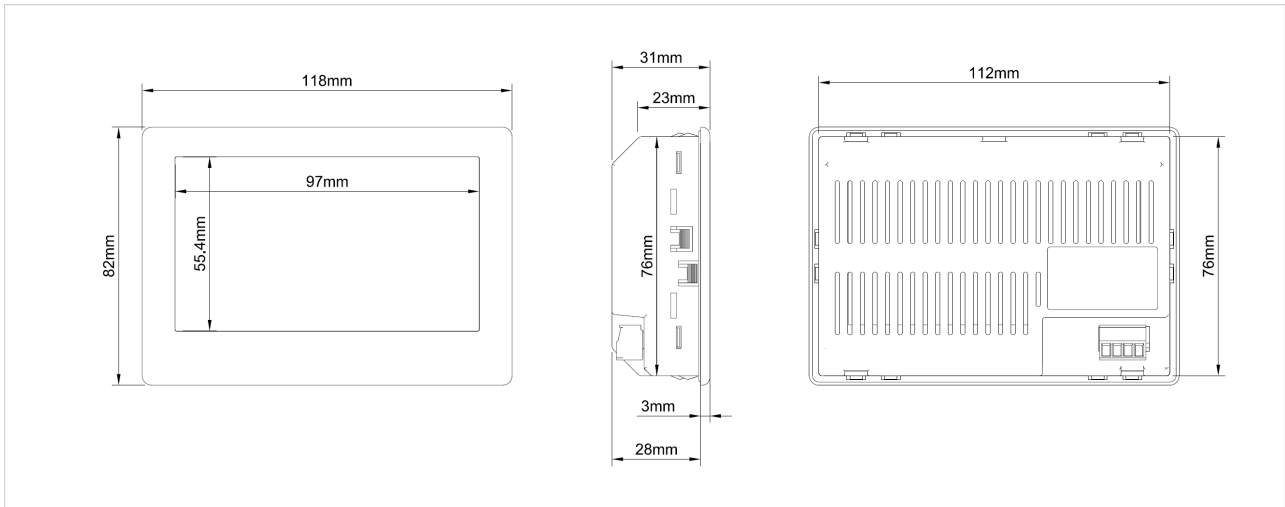

Control Module:

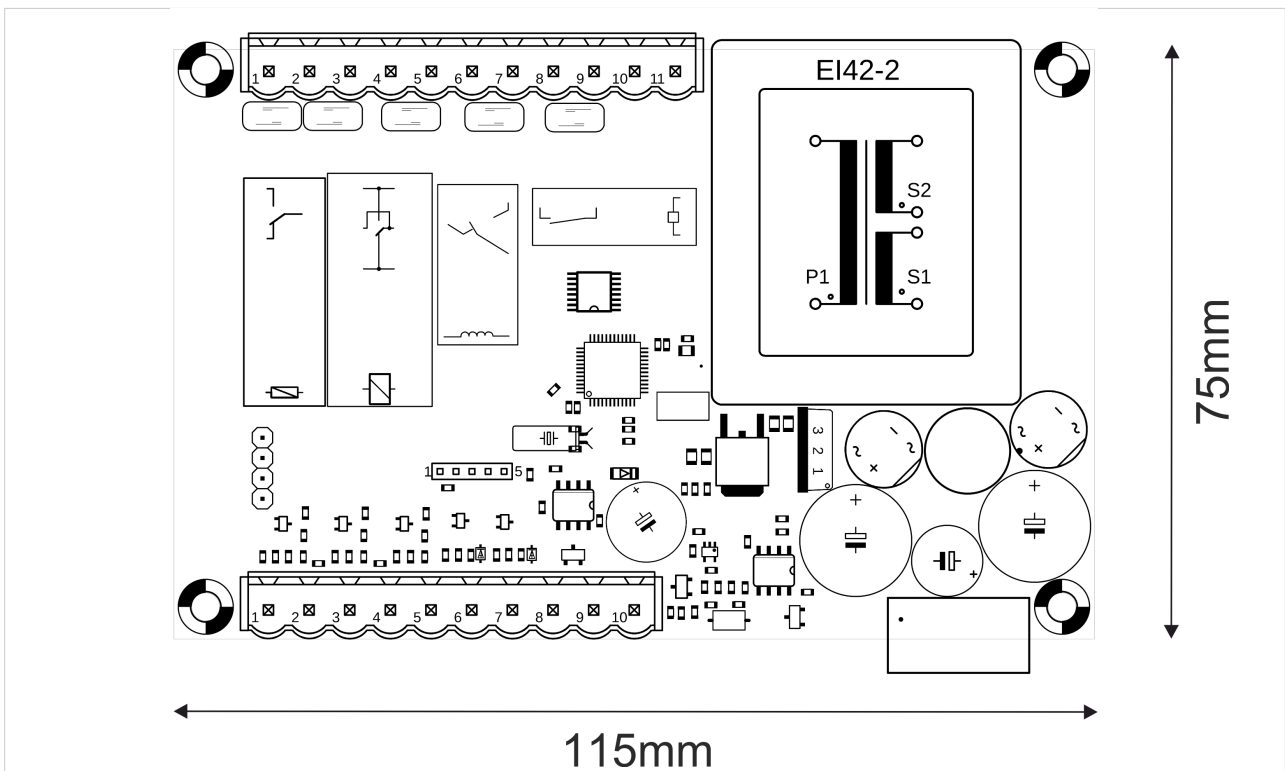

Panel Commands

Changing Parameter Values

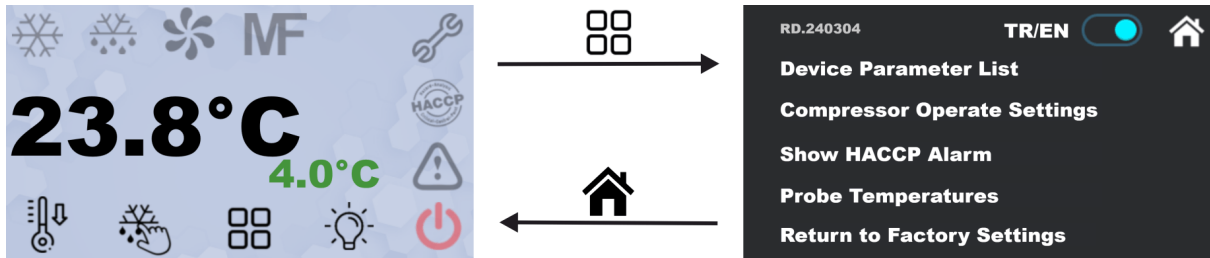

When the device is on the main screen, clicking the button enters the configuration screen.

Within the configuration screen, clicking the button returns the device to the "Main Screen."

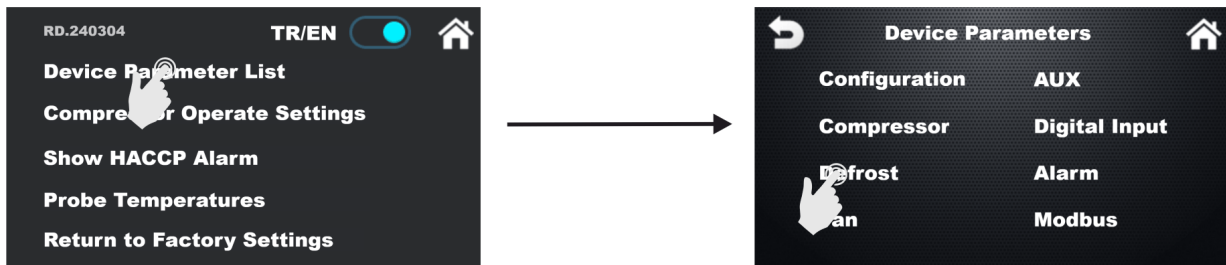

To enter the "Parameter Menu", you need to click on the Device Parameter List.

While in the "Parameter Menu", clicking on the text corresponding to the parameter opens the relevant parameter page. If you click on the text "Defrost", it enters the defrost parameter menu.

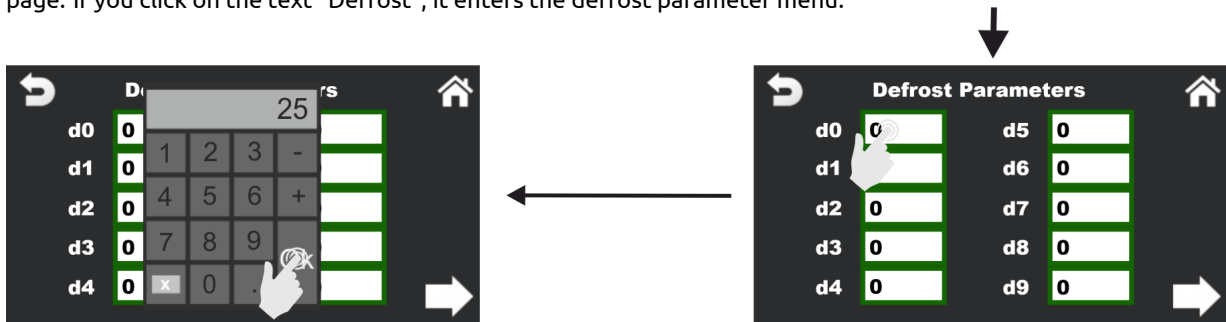

To enter the "Parameter Menu", you need to click on the Device Parameter List. While in the "Parameter Menu", clicking on the text corresponding to the parameter opens the relevant parameter page. If you click on the text "Defrost", it enters the defrost parameter menu.

Regardless of the menu you are in, clicking on the icon returns the device to the "Main Screen." If you click on the icon, it takes you back to the previous page.

Displaying Probe Temperatures

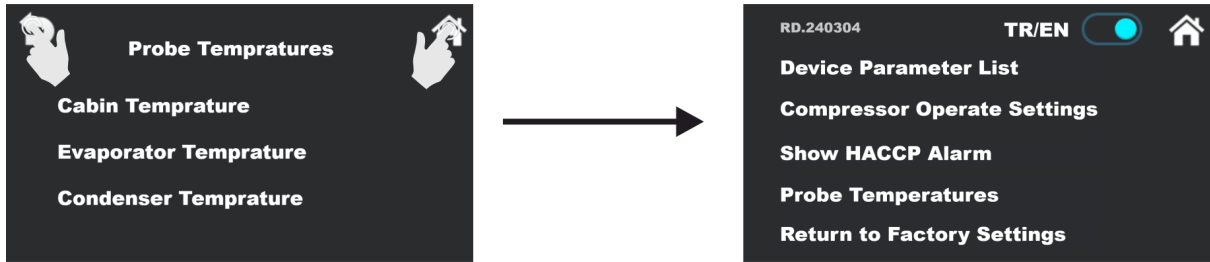

While in the configuration screen, clicking on the text Probe Temperature Display enters the screen where probe temperatures are displayed.

Displaying HACCP Alarms

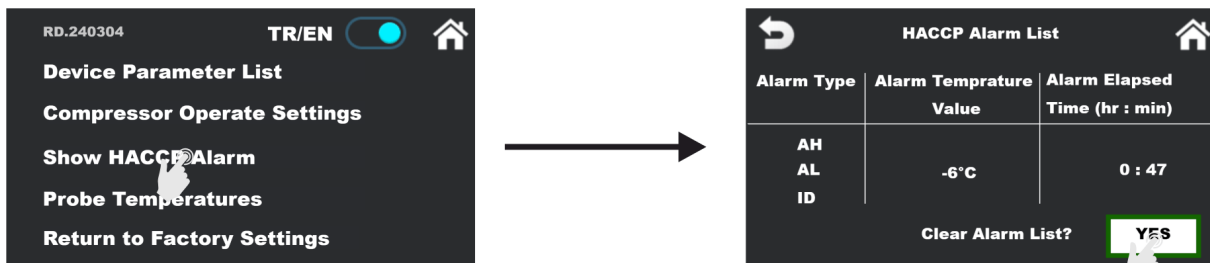

While on the configuration page, clicking on the Show HACCP Alarm text navigates to the page where HACCP alarms are displayed. Here, the temperature values at which the alarms occurred and the duration for which they remained active can be viewed. If the button is clicked, all generated alarms will be deleted.



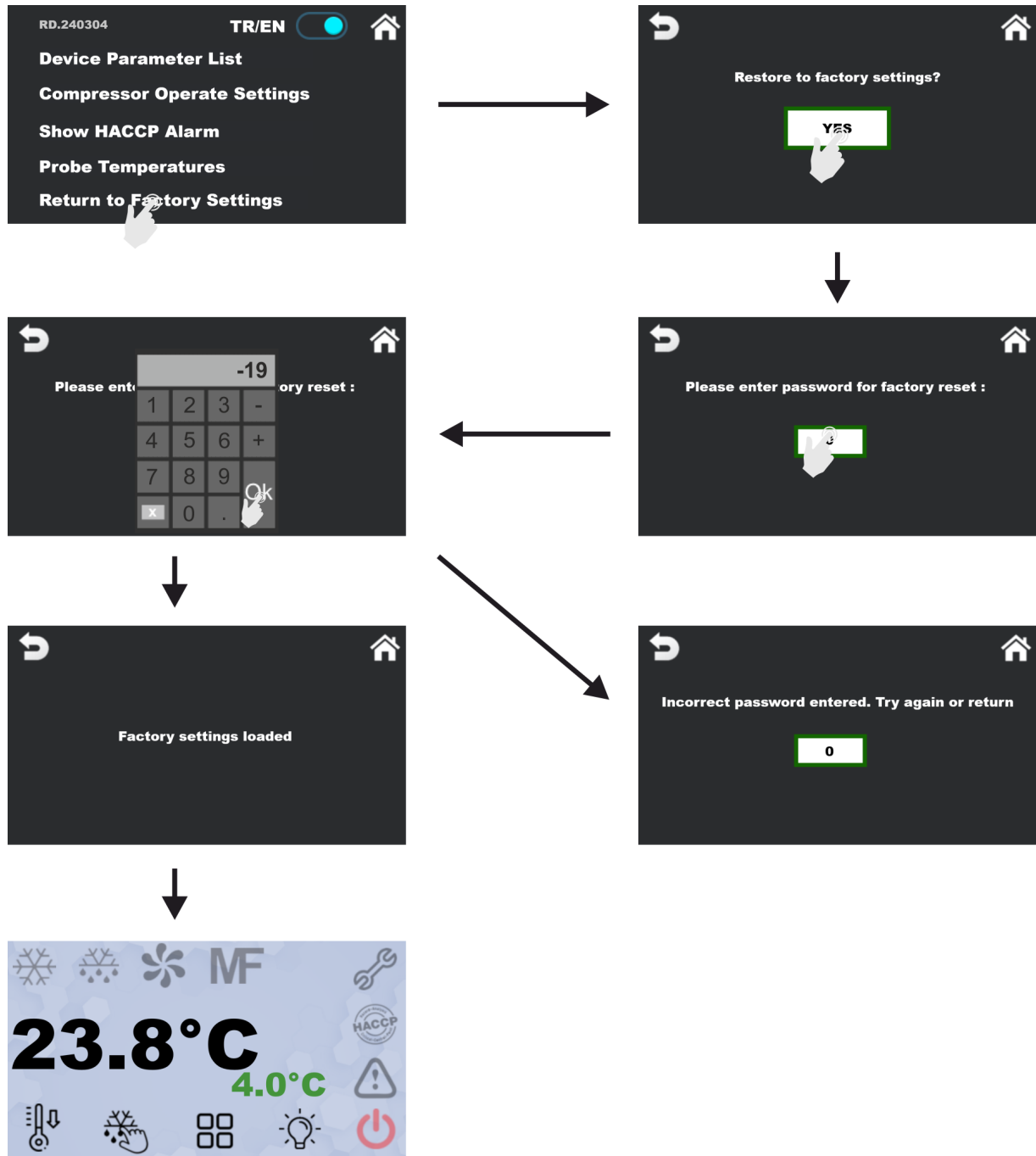



Factory Reset

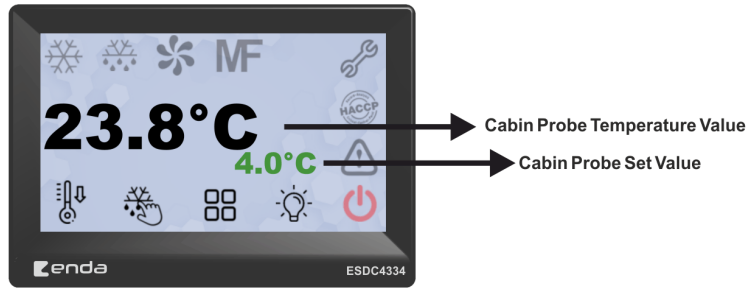





After clicking the password button, if "-19" is entered using the keyboard and the "Ok" button is pressed, a message indicating that the password has been entered correctly will be displayed on the screen for 2 seconds. Then, the device will return to the "Main Screen" and start operating according to the factory settings. If the password is entered incorrectly, a "Incorrect Password Entered" warning will appear, and the password will need to be entered again.

Icons and Button Definitions



Icon Definitions	
	Compressor Icon Illuminates when the compressor is operating; blinks when protection delays are active; turns off when not operating.
	Defrost Icon Illuminates during defrosting; blinks when protection delays and drip-drain times are active; turns off when not operating.
	Evaporator Fan Icon Illuminates when the evaporator fan output is active; remains off when not operating.
MF	Aux Icon Illuminates when the auxiliary output is active; remains off when not operating.
	HACCP Alarm Icon Blinks when a new alarm occurs; illuminates if the last alarm was acknowledged; turns off once all alarms are acknowledged.
	Energy Saving Icon Illuminates when energy-saving mode is active; remains off otherwise.
	Compressor Maintenance Icon Illuminates when the compressor has reached its working time limit.
	Alarm/Error Icon Illuminates during alarm states and sensor errors.

Button Definitions	
	Rapid Cooling/Heating Button In operational mode, this button initiates manual fast cooling when clicked (when the device is in defrost mode and the drip drain time is not active). When the r6 time is completed or if the button is clicked again, the manual fast cooling process ends. The button is illuminated while manual fast cooling is active and turns off when manual fast cooling is deactivated.
	Manual Defrost Button This button serves the function of initiating/ending the manual defrost process. In operational mode (when the device is not in fast cooling mode and the drip drain time is not active), clicking the button starts the defrost process. When the d3 time is completed or if the button is clicked again, the manual defrost process ends. The button is black while manual defrost is active and turns grey when manual defrost is deactivated.
	Menu Enter Button When the menu entry button is clicked on the main screen, the device menu is accessed.
	Aux Button In operational mode, it performs the function of enabling and disabling the AUX output. The button lights up when the output is active, and the button goes off when the output is deactivated.
	On/Off Button When the device is in the ON state, pressing the button transitions the device to the OFF position, closing all outputs, and the button color turns red. When the device is in the OFF state, pressing the button again transitions the device to the ON position, returning to normal operation. Meanwhile, the button color changes to grey.

Error - Warning - Alarm Definitions

	Definition	Outputs
Cabin Probe Error	Cabin Probe Error - Check the cabin probe connection. - The compressor operates according to parameters C4 and C5.	All outputs are turned off.
Evap Probe Error	Evaporator Probe Error - Check evaporator probe connection. - Check parameter P4.	Defrost output is turned off
Condenser Probe Error	Condenser Probe Error - Check condenser probe connection.	The condenser fan output is turned off.
AL	Low Temperature Alarm - Check parameters A0, A1, and A2.	The outputs remain unchanged.
AH	High Temperature Alarm - Check parameters A0, A4 and A5.	The outputs remain unchanged.
id	Door Open Alarm - Check the door digital input. - Check parameters i0 and i1.	Check the i0 parameter.
iA	Multi-Function Input Alarm - Check the multi-function digital input. - Check parameters i5 and i6.	Check the i5 parameter.
LP	Low Pressure Alarm - Check parameters i5 and i6.	The outputs remain unchanged.
iSd	High Pressure Alarm - Check parameters i5 and i6.	The outputs remain unchanged.
COH	Condenser Probe Overheating Alarm - Check the condenser probe. - Check parameter C6.	The outputs remain unchanged.
CSD	Condenser Probe Overheating After Compressor Shutdown Alarm - Check the condenser probe. - Check parameters C7 and C8.	Compressor output is turned off.
dFd	Defrost Alarm	The outputs remain unchanged.

SRS	Service Alarm - Check parameters S1 and S2.	All outputs are turned off.
-----	---	-----------------------------

Configuration Parameters

Display	Description	Min	Max	Unit	Default
SEt	Set value	r1	r2	°C/°F	4
cA1	Cabinet probe offset value	-25	25	-	0
cA2	Evaporator probe offset value	-25	25	-	0
cA3	Auxiliary probe offset value	-25	25	-	0
P1	Decimal point 0: No 1: Yes	0	1	-	0
P2	Temperature unit °C: Celcius °F: Fahrenheit	°C	°F	-	°C
P3	Evaporator probe function 0: Not used 1: Used for defrost and fan control 2: Used for fan control only	0	2	-	1
P4	Condenser probe use 0: Not used 1: Used	0	1	-	0
P5	Value displayed 0: Cabinet temperature 1: Setpoint 2: Evaporator temperature 3: Condenser temperature	0	3	-	0
P8	Display refresh time	1	250	ds	1
r0	Setpoint differential	1	20	-	3
r1	Setpoint lower limit	-60	r2	°C/°F	-40
r2	Setpoint upper limit	r1	150	°C/°F	50
r3	Enable setpoint lock 0: Disable setpoint lock 1: Enable setpoint lock	0	1	-	0

Display	Description	Min	Max	Unit	Default
r4	Setpoint offset in energy saving	0	99	°C/°F	0
r5	Type of control mode 0: Cold mode 1: Hot mode	0	1	-	0
r6	Setpoint offset in overcooling/overheating	0	99	°C/°F	0
r7	Duration overcooling/overheating	0	240	min	2
r8	Down key additional function 0: Disabled 1: Overcooling/overheating 2: Energy saving	0	2	-	2

Compressor Protection Parameters

Display	Description	Min	Max	Unit	Default
c0	Compressor-on delay from power-on	0	240	min	0
c2	Minimum compressor-off time	0	240	min	3
c3	Minimum compressor-on time	0	240	sec	0
c4	Compressor-off time in cabinet probe alarm	0	240	min	10
c5	Compressor-on time in cabinet probe alarm	0	240	min	10
c6	If the condenser temperature is higher than this value, the condenser temperature alarm 'COH' becomes active	0	150	°C/°F	80
c7	If the condenser temperature is higher than this value, the condenser temperature alarm 'Csd' becomes active	0	150	°C/°F	90
c8	Csd alarm delay	0	15	min	1
c10	Compressor run time limit. When the compressor runs for more than this time, the maintenance led turns on	0	999	hr	0

Defrost Control Parameters

Display	Description	Min	Max	Unit	Default
d0	Automatic defrost interval	0	99	hr	8
d1	Type of defrost 0: Electric (Compressor off) defrost 1: Hot gas (compressor on) defrost 2: Compressor stopped	0	2	-	0
d2	Defrost end threshold (P3 must be 1)	-60	150	°C/°F	2
d3	Defrost duration	0	99	min	30
d4	Defrost starts with energy 0: Defrost does not start with energy 1: Defrost starts with energy	0	1	-	0
d5	Defrost delay from power-on	0	99	min	0
d6	Value displayed when defrosting 0: The cabin temperature is displayed 1: Locked display 2: During defrost, "dEF" message is displayed	0	2	-	1
d7	Dripping time	0	15	min	4
d8	Defrost interval count mode 0: The time counter (d0) between two defrosts is decremented regardless of any condition 1: The time counter (d0) between two defrosts is decremented only as long as the compressor is running 2: The time counter (d0) between two defrosts is decremented only as long as the evaporator probe temperature is less than d9 par. (P2 < d9) 3: Adaptive defrost	0	3	-	0
d9	Evaporation threshold for automatic defrost interval count (when d8=2)	-60	99	°C/°F	0
d11	Defrost alarm max. is turned off if the display time has been reached 0: The defrost alarm is not turned off 1: The defrost alarm is turned off	0	1	-	0
d15	Compressor-on consecutive time for hot gas defrost (when d1=1)	0	99	min	0
d16	Pre-dripping time for hot gas defrost	0	99	min	0
d18	In defrost normal operation mode, if the sum of the times during which the evaporator temperature is below the calculated ideal evaporation temperature reaches this time, defrost is activated	0	99	min	40

Display	Description	Min	Max	Unit	Default
d19	Defrost is active if the evaporator probe temperature (calculated evap temperature-d19) is lower than this value	0	150	°C/°F	3
d22	Adaptive defrost evap probe termination temperature	-10	10	°C/°F	-2

Alarm Control Parameters

Display	Description	Min	Max	Unit	Default
A0	Select value for high/low temperature alarms 0: Cabinet probe 1: Evaporator probe	0	1	-	0
A1	Low temperature alarm threshold	-60	A4	°C/°F	-50
A2	Type of low temperature alarm 0: Disabled 1: The alarm activation value becomes SP- A1 2: The alarm activation value becomes A1	0	2	-	2
A4	High temperature alarm threshold	A1	99	°C/°F	60
A5	Type of high temperature alarm 0: Disabled 1: Alarm activation value becomes SP+A4 2: The alarm activation value becomes A4	0	2	-	2
A6	High temperature alarm delay from power-on	0	240	min	120
A7	High/low temperature alarm delay	0	240	min	15
A8	High temperature alarm delay post-defrosting	0	240	min	15
A9	High temperature alarm delay from door closure	0	240	min	15
A11	High/low temperature alarm reset differential	1	15	-	2
S1	Service alarm set value	-60	150	°C/°F	65
S2	Service alarm stop value	-60	150	°C/°F	50

Fan Control Parameters

Display	Description	Min	Max	Unit	Default
F0	Evaporator fan mode in normal function 0: Off 1: On 2: On if compressor on 3: Thermoregulated(with room temperature + F1) 4: Thermoregulated(with room temperature + F1) if compressor on 5: Function of F6 6: Thermoregulated(with F1) 7: Thermoregulated(with F1) if compressor on	0	7	-	1
F1	Evaporator fan regulation threshold	-60	150	°C/°F	-4
F2	Evaporator fan mode in defrost and drip mode 0: Off 1: On 2: Dependent function of F0	0	2	-	0
F3	Post-dripping delay of the evap. fan	0	15	min	2
F4	Time evaporator fan off in energy saving	0	240	sec	30
F5	Time evaporator fan on in energy saving	0	240	sec	30
F6	Function for high/low humidity 0: For low humidity (with F17 and F18 if compressor off, on if compressor on) 1: For high humidity(on)	0	1	-	0
F7	Evaporator fans on threshold from dripping (relative to setpoint)	-60	99	°C/°F	5
F8	Evaporator fan regulation threshold differential	1	20	-	2
F9	Evaporator fan off delay from compressor off(if F0 = 2 or 5)	0	240	sec	10
F11	Condenser fan on threshold according to condenser probe	0	99	°C/°F	15
F12	Condenser fan off delay from compressor off	0	240	sec	30
F17	Time evaporator fan off in low humidity	0	240	sec	60
F18	Time evaporator fan on in low humidity	0	240	sec	10

Digital Input Parameters

Display	Description	Min	Max	Unit	Default
i0	Door switch input functions 0: Disabled 1: Compressor and evap. fan off 2: Evap. fan off 3: Cabinet light on 4: Compressor and evap. fan off, cabinet light on 5: Evap. fan off, cabinet light on	0	5	-	5
i1	Door digital input activation 0: N.O. 1: N.C.	0	1	-	0
i2	Door open alarm delay	0	120	min	30
i3	Max. time for inhibiting regulation with door open (If 0 is selected, the effect continues until the door closes.)	0	120	min	15
i4	Door digital input alarm storage 0: Passive 1: Active	0	1	-	0
i5	Multi-purpose input function 0: Disabled 1: Energy saving 2: Alarm iA 3: Alarm iSd 4: Enable aux output 5: Switches device on/off 6: Alarm LP	0	6	-	0
i6	Multifunction digital input activation 0: N.O. 1: N.C.	0	1	-	0
i7	Multi-purpose input alarm delay	0	120	min	0
i8	Number of multi-purpose input activations for high pressure alarm (if i5 = 3)	0	15	-	0
i9	Counter reset time for high pressure alarm	1	999	min	240
i10	Door closed consecutive time for energy saving	0	999	min	0

AUX Output Parameters

Display	Description	Min	Max	Unit	Default
u1	Aux relay control 0: As a lighting output (i0 and u2 must be controlled) 1: As a demister output (must check u6 par) 2: As AUX output (u2 must be checked) 3: As alarm output (u4 must be checked) 4: As evaporator output (u7 and u8 should be checked) 5: As the condenser fan output according to the condenser temperature (P4, F11, F12 should be checked)	0	5	-	0
u2	Activating the lighting and AUX outputs on and off when the device is manually off/on 0: Passive 1: Active	0	1	-	0
u4	Enable silencing alarm output 0: Passive 1: Active	0	1	-	1
u6	Duration demisting on	1	120	min	5
u7	In order for the evaporator output to be active, the cabin temperature must be above this adjusted parameter	0	99	°C/°F	2
u8	Evaporatör output activation 0: N.O. 1: N.C.	0	1	-	0
u9	Enable alarm buzzer 0: Passive 1: Active	0	1	-	0

Modbus Communication Parameters

Display	Description	Min	Max	Unit	Default
h1	Modbus slave device address	1	247	-	1
h2	Baud rate 0: OFF 1: 1200 bps 2: 2400 bps 3: 4800 bps 4: 9600 bps 5: 19200 bps 6: 38400 bps 7: 56000 bps 8: 57600 bps 9: 115200 bps	0	9	bps	4

Energy Saving Parameters

Display	Description	Min	Max	Unit	Default
hE2	Maximum duration energy saving (if it's 0 then it is until door opened)	0	999	min	2

ESDC4334 Split Digital Thermostat Modbus Map

Holding Registers

Register Addresses		Data Type	Description	Display	Permission
Decimal	Hex				
0	0x0000	word	Set value [°C/°F]	SEt	Readable Writable
1	0x0001	word	Cabinet probe offset value	cA1	Readable Writable
2	0x0002	word	Evaporator probe offset value	cA2	Readable Writable
3	0x0003	word	Auxiliary probe offset value	cA3	Readable Writable

Register Addresses		Data Type	Description	Display	Permission
Decimal	Hex				
4	0x0004	word	Evaporator probe function 0: Not used 1: Used for defrost and fan control 2: Used for fan control only	P3	Readable Writable
5	0x0005	word	Value displayed 0: Cabinet temperature 1: Setpoint 2: Evaporator temperature 3: Condenser temperature	P5	Readable Writable
6	0x0006	word	Display refresh time [ds]	P8	Readable Writable
7	0x0007	word	Setpoint differential	r0	Readable Writable
8	0x0008	word	Setpoint lower limit [°C/°F]	r1	Readable Writable
9	0x0009	word	Setpoint upper limit [°C/°F]	r2	Readable Writable
10	0x000A	word	Setpoint offset in energy saving [°C/°F]	r4	Readable Writable
11	0x000B	word	Setpoint offset in overcooling/overheating [°C/°F]	r6	Readable Writable
12	0x000C	word	Duration overcooling/overheating [min]	r7	Readable Writable
13	0x000D	word	Down key additional function 0: Disabled 1: Overcooling/overheating 2: Energy saving	r8	Readable Writable
14	0x000E	word	Compressor-on delay from power-on [min]	c0	Readable Writable
15	0x000F	word	Minimum compressor-off time [min]	c2	Readable Writable
16	0x0010	word	Minimum compressor-on time [sec]	c3	Readable Writable
17	0x0011	word	Compressor-off time in cabinet probe alarm [min]	c4	Readable Writable
18	0x0012	word	Compressor-on time in cabinet probe alarm [min]	c5	Readable Writable
19	0x0013	word	If the condenser temperature is higher than this value, the condenser temperature alarm 'COH' becomes active [°C/°F]	c6	Readable Writable

Register Addresses		Data Type	Description	Display	Permission
Decimal	Hex				
20	0x0014	word	If the condenser temperature is higher than this value, the condenser temperature alarm 'Csd' becomes active [°C/°F]	c 7	Readable Writable
21	0x0015	word	Csd alarm delay [min]	c 8	Readable Writable
22	0x0016	word	Compressor run time limit. When the compressor runs for more than this time, the maintenance led turns on [hr]	c 10	Readable Writable
23	0x0017	word	Automatic defrost interval [hr]	d 0	Readable Writable
24	0x0018	word	Type of defrost 0: Electric (Compressor off) defrost 1: Hot gas (compressor on) defrost 2: Compressor stopped	d 1	Readable Writable
25	0x0019	word	Defrost end threshold (P3 must be 1) [°C/°F]	d 2	Readable Writable
26	0x001A	word	Defrost duration [min]	d 3	Readable Writable
27	0x001B	word	Defrost delay from power-on [min]	d 5	Readable Writable
28	0x001C	word	Value displayed when defrosting 0: The cabin temperature is displayed 1: Locked display 2: During defrost, "dEF" message is displayed	d 6	Readable Writable
29	0x001D	word	Dripping time [min]	d 7	Readable Writable
30	0x001E	word	Defrost interval count mode 0: The time counter (d0) between two defrosts is decremented regardless of any condition 1: The time counter (d0) between two defrosts is decremented only as long as the compressor is running 2: The time counter (d0) between two defrosts is decremented only as long as the evaporator probe temperature is less than d9 par. (P2 < d9) 3: Adaptive defrost	d 8	Readable Writable
31	0x001F	word	Evaporation threshold for automatic defrost interval count (when d8=2) [°C/°F]	d 9	Readable Writable
32	0x0020	word	Compressor-on consecutive time for hot gas defrost (when d1=1) [min]	d 15	Readable Writable
33	0x0021	word	Pre-dripping time for hot gas defrost [min]	d 16	Readable Writable

Register Addresses		Data Type	Description	Display	Permission
Decimal	Hex				
34	0x0022	word	In defrost normal operation mode, if the sum of the times during which the evaporator temperature is below the calculated ideal evaporation temperature reaches this time, defrost is activated [min]	d 18	Readable Writable
35	0x0023	word	Defrost is active if the evaporator probe temperature (calculated evap temperature-d19) is lower than this value [°C/°F]	d 19	Readable Writable
36	0x0024	word	Adaptive defrost evap probe termination temperature [°C/°F]	d22	Readable Writable
37	0x0025	word	Low temperature alarm threshold [°C/°F]	A 1	Readable Writable
38	0x0026	word	Type of low temperature alarm 0: Disabled 1: The alarm activation value becomes SP- A1 2: The alarm activation value becomes A1	A2	Readable Writable
39	0x0027	word	High temperature alarm threshold [°C/°F]	A4	Readable Writable
40	0x0028	word	Type of high temperature alarm 0: Disabled 1: Alarm activation value becomes SP+A4 2: The alarm activation value becomes A4	A5	Readable Writable
41	0x0029	word	High temperature alarm delay from power-on [min]	A6	Readable Writable
42	0x002A	word	High/low temperature alarm delay [min]	A7	Readable Writable
43	0x002B	word	High temperature alarm delay post-defrosting [min]	A8	Readable Writable
44	0x002C	word	High temperature alarm delay from door closure [min]	A9	Readable Writable
45	0x002D	word	High/low temperature alarm reset differential	A 11	Readable Writable
46	0x002E	word	Service alarm set value [°C/°F]	5 1	Readable Writable
47	0x002F	word	Service alarm stop value [°C/°F]	52	Readable Writable

Register Addresses		Data Type	Description	Display	Permission
Decimal	Hex				
48	0x0030	word	Evaporator fan mode in normal function 0: Off 1: On 2: On if compressor on 3: Thermoregulated(with room temperature + F1) 4: Thermoregulated(with room temperature + F1) if compressor on 5: Function of F6 6: Thermoregulated(with F1) 7: Thermoregulated(with F1) if compressor on	F0	Readable Writable
49	0x0031	word	Evaporator fan regulation threshold [°C/°F]	F1	Readable Writable
50	0x0032	word	Evaporator fan mode in defrost and drip mode 0: Off 1: On 2: Dependent function of F0	F2	Readable Writable
51	0x0033	word	Post-dripping delay of the evap. fan [min]	F3	Readable Writable
52	0x0034	word	Time evaporator fan off in energy saving [sec]	F4	Readable Writable
53	0x0035	word	Time evaporator fan on in energy saving [sec]	F5	Readable Writable
54	0x0036	word	Function for high/low humidity 0: For low humidity (with F17 and F18 if compressor off, on if compressor on) 1: For high humidity(on)	F6	Readable Writable
55	0x0037	word	Evaporator fans on threshold from dripping (relative to setpoint) [°C/°F]	F7	Readable Writable
56	0x0038	word	Evaporator fan regulation threshold differential	F8	Readable Writable
57	0x0039	word	Evaporator fan off delay from compressor off(if F0 = 2 or 5) [sec]	F9	Readable Writable
58	0x003A	word	Condenser fan on threshold according to condenser probe [°C/°F]	F11	Readable Writable
59	0x003B	word	Condenser fan off delay from compressor off [sec]	F12	Readable Writable
60	0x003C	word	Time evaporator fan off in low humidity [sec]	F17	Readable Writable
61	0x003D	word	Time evaporator fan on in low humidity [sec]	F18	Readable Writable

Register Addresses		Data Type	Description	Display	Permission
Decimal	Hex				
62	0x003E	word	Door switch input functions 0: Disabled 1: Compressor and evap. fan off 2: Evap. fan off 3: Cabinet light on 4: Compressor and evap. fan off, cabinet light on 5: Evap. fan off, cabinet light on	10	Readable Writable
63	0x003F	word	Door open alarm delay [min]	12	Readable Writable
64	0x0040	word	Max. time for inhibiting regulation with door open (If 0 is selected, the effect continues until the door closes.) [min]	13	Readable Writable
65	0x0041	word	Multi-purpose input function 0: Disabled 1: Energy saving 2: Alarm iA 3: Alarm iSd 4: Enable aux output 5: Switches device on/off 6: Alarm LP	15	Readable Writable
66	0x0042	word	Multi-purpose input alarm delay [min]	17	Readable Writable
67	0x0043	word	Number of multi-purpose input activations for high pressure alarm (if i5 = 3)	18	Readable Writable
68	0x0044	word	Counter reset time for high pressure alarm [min]	19	Readable Writable
69	0x0045	word	Door closed consecutive time for energy saving [min]	110	Readable Writable
70	0x0046	word	Aux relay control 0: As a lighting output (i0 and u2 must be controlled) 1: As a demister output (must check u6 par) 2: As AUX output (u2 must be checked) 3: As alarm output (u4 must be checked) 4: As evaporator output (u7 and u8 should be checked) 5: As the condenser fan output according to the condenser temperature (P4, F11, F12 should be checked)	u1	Readable Writable
71	0x0047	word	Duration demisting on [min]	u6	Readable Writable
72	0x0048	word	In order for the evaporator output to be active, the cabin temperature must be above this adjusted parameter [°C/°F]	u7	Readable Writable
73	0x0049	word	Maximum duration energy saving (if it's 0 then it is until door opened) [min]	hE2	Readable Writable

Register Addresses		Data Type	Description	Display	Permission
Decimal	Hex				
74	0x004A	word	Modbus slave device address	h1	Readable Writable
75	0x004B	word	Baud rate [bps] 0: OFF 1: 1200 bps 2: 2400 bps 3: 4800 bps 4: 9600 bps 5: 19200 bps 6: 38400 bps 7: 56000 bps 8: 57600 bps 9: 115200 bps	h2	Readable Writable

Coils

Register Addresses		Data Type	Description	Display	Permission
Decimal	Hex				
0	0x0000	bit	Decimal point 0: No 1: Yes	P1	Readable Writable
1	0x0001	bit	Temperature unit 0: Celcius 1: Fahrenheit	P2	Readable Writable
2	0x0002	bit	Condenser probe use 0: Not used 1: Used	P4	Readable Writable
3	0x0003	bit	Enable setpoint lock 0: Disable setpoint lock 1: Enable setpoint lock	r3	Readable Writable
4	0x0004	bit	Type of control mode 0: Cold mode 1: Hot mode	r5	Readable Writable
5	0x0005	bit	Defrost starts with energy 0: Defrost does not start with energy 1: Defrost starts with energy	d4	Readable Writable
6	0x0006	bit	Defrost alarm max. is turned off if the display time has been reached 0: The defrost alarm is not turned off 1: The defrost alarm is turned off	d11	Readable Writable

Register Addresses		Data Type	Description	Display	Permission
Decimal	Hex				
7	0x0007	bit	Select value for high/low temperature alarms 0: Cabinet probe 1: Evaporator probe	00	Readable Writable
8	0x0008	bit	Door digital input activation 0: N.O. 1: N.C.	01	Readable Writable
9	0x0009	bit	Door digital input alarm storage 0: Passive 1: Active	04	Readable Writable
10	0x000A	bit	Multifunction digital input activation 0: N.O. 1: N.C.	06	Readable Writable
11	0x000B	bit	Activating the lighting and AUX outputs on and off when the device is manually off/on 0: Passive 1: Active	02	Readable Writable
12	0x000C	bit	Enable silencing alarm output 0: Passive 1: Active	04	Readable Writable
13	0x000D	bit	Evaporatör output activation 0: N.O. 1: N.C.	08	Readable Writable
14	0x000E	bit	Enable alarm buzzer 0: Passive 1: Active	09	Readable Writable
15	0x000F	bit	Fast cooling 0: Overcooling passive 1: Overcooling active		Readable Writable
16	0x0010	bit	Starting/stopping manual defrost 0: Manual defrost passive 1: Manual defrost active		Readable Writable
17	0x0011	bit	Device manual switch on/off 0: Device is on 1: Device is off		Readable Writable
18	0x0012	bit	Loading default parameters 0: Passive 1: Active		Readable Writable

Register Addresses		Data Type	Description	Display	Permission
Decimal	Hex				
19	0x0013	bit	Clearing generated HACCP alarms 0: Passive 1: Active		Readable Writable
20	0x0014	bit	Compressor runtime reset 0: Passive 1: Active		Readable Writable
21	0x0015	bit	Aux relay control 0: Passive 1: Active		Readable Writable
22	0x0016	bit	Alarm silence control 0: Passive 1: Active		Readable Writable
23	0x0017	bit	Key lock control 0: Passive 1: Active		Readable Writable
24	0x0018	bit	Defrost alarm silence control 0: Passive 1: Active		Readable Writable
25	0x0019	bit	HACCP new alarm control 0: Passive 1: Active		Readable Writable
26	0x001A	bit	Energy saving mode 0: Energy saving passive 1: Energy saving active		Readable Writable
27	0x001B	bit	Fast heating 0: Overheating passive 1: Overheating active		Readable Writable
28	0x001C	bit	Relay output test 0: Relay outputs passive 1: Relay outputs active		Readable Writable

Input Registers

Register Addresses		Data Type	Description	Display	Permission
Decimal	Hex				
0	0x0000	word	Measured cabinet temperature value [°C / °F]		Readable
1	0x0001	word	Measured evaporator probe temperature value [°C / °F]		Readable
2	0x0002	word	Measured condenser probe temperature value [°C / °F]		Readable
3	0x0003	word	Cabinet probe error status		Readable
4	0x0004	word	Evap. probe error status		Readable
5	0x0005	word	Condenser probe error status		Readable
6	0x0006	word	HACCP AH alarm temperature value [°C / °F]		Readable
7	0x0007	word	HACCP AL alarm temperature value [°C / °F]		Readable
8	0x0008	word	Duration of HACCP AH alarm [min]		Readable
9	0x0009	word	Duration of HACCP AL alarm [min]		Readable
10	0x000A	word	Duration of HACCP ID alarm [min]		Readable
11	0x000B	word	Condenser probe overheat alarm		Readable
12	0x000C	word	Compressor shutdown alarm after condenser probe warms up		Readable
13	0x000D	word	HACCP Alarm status		Readable
14	0x000E	word	Service alarm status		Readable
15	0x000F	word	Alarm status		Readable
16	0x0010	word	Compressor running time [min]		Readable
17	0x0011	word	Compressor running time [hour]		Readable
18	0x0012	word	Compressor status information		Readable
19	0x0013	word	Defrost status information		Readable
20	0x0014	word	Fan status information		Readable
21	0x0015	word	AUX status information		Readable
22	0x0016	word	Digital input status information		Readable
23	0x0017	word	Multifunction input status information		Readable

Discrete Inputs

Register Addresses		Data Type	Description	Display	Permission
Decimal	Hex				
0	0x0000	bit	Control output status (0 = OFF, 1 = ON)		Readable
1	0x0001	bit	Defrost output status (0 = OFF, 1 = ON)		Readable
2	0x0002	bit	Fan output status (0 = OFF, 1 = ON)		Readable
3	0x0003	bit	Aux output status (0 = OFF, 1 = ON)		Readable
4	0x0004	bit	Compressor run time limit control (1 = Run limit exceeded)		Readable
5	0x0005	bit	dFd alarm status (0 = OFF, 1 = ON)		Readable
6	0x0006	bit	Message before melting		Readable
7	0x0007	bit	Door digital input active status (0 = OFF, 1 = ON)		Readable
8	0x0008	bit	Multi-function digital input active status (0 = OFF, 1 = ON)		Readable
9	0x0009	bit	Cabinet probe failure (0 = No error, 1 = Error present) (All outputs are disabled)	Pr 1	Readable
10	0x000A	bit	Evaporator probe failure (0 = No error, 1 = Error present) (Defrost output is disabled)	Pr 2	Readable
11	0x000B	bit	Condenser probe failure (0 = No error, 1 = Error present) (Condenser fan output is disabled)	Pr 3	Readable
12	0x000C	bit	Low temperature alarm (0 = No alarm, 1 = Alarm present)	AL	Readable
13	0x000D	bit	High temperature alarm (0 = No alarm, 1 = Alarm present)	Ah	Readable
14	0x000E	bit	Door open alarm (0 = No alarm, 1 = Alarm present)	id	Readable
15	0x000F	bit	Multi-function digital input alarm (0 = No alarm, 1 = Alarm present)	iA	Readable
16	0x0010	bit	Low pressure alarm (0 = No alarm, 1 = Alarm present)	LP	Readable
17	0x0011	bit	High pressure alarm (0 = No alarm, 1 = Alarm present)	hP	Readable
18	0x0012	bit	Condenser probe overheat alarm (0 = No alarm, 1 = Alarm present)	coh	Readable
19	0x0013	bit	Compressor shutdown after condenser overheat alarm (0 = No alarm, 1 = Alarm present)	cdh	Readable
20	0x0014	bit	Service alarm (0 = No alarm, 1 = Alarm present) (All outputs are disabled)	sr	Readable