



Please read this document carefully before using this product. The guarantee will be invalidated if the device is damaged by not following instructions detailed in the manual. The company shall not be responsible for any damage or losses however caused, which may be experienced as a result of the installation or use of this product.

# ENDA EDT5411A DIGITAL THERMOSTAT

Thank you for choosing ENDA EDT5411A temperature controller.

- ▶ 54x94mm.
- ▶ On-Off control.
- ▶ Relay output for cooling or heating control.
- ▶ Single NTC probe input.
- ▶ Offset value can be entered for NTC input.
- ▶ Compressor protection parameters can be entered.
- ▶ In case of probe failure, output status can be set to ON, OFF or periodic.
- ▶ Upper and Lower setpoint value limits can be adjusted.
- ▶ Defrosting duration and intervals can be adjusted.
- ▶ 6 Different warning tone selections.
- ▶ Lower and upper alarm limit can be adjusted depending on set value.
- ▶ Temperature unit can be selected °C or °F.
- ▶ Digital input ;
  - External alarm
  - Initiate defrost
- ▶ Transfer device parameter settings with ENDAKEY
  - No power-up required.
- ▶ RS485 ModBus protocol communication feature (optional).
- ▶ CE marked according to European Norms.



Order Code : EDT5411A - <span style="border: 1px solid black; padding: 2px;">  </span> - <span style="border: 1px solid black; padding: 2px;">  </span> - <span style="border: 1px solid black; padding: 2px;">  </span>		
1	2	3
<b>1 - Supply Voltage</b> 230.....230V AC  LV.....10-30V DC / 8-24V AC	<b>2-Output</b> 20.....20A Relay output  08.....08A Relay output	<b>3 - Modbus</b> RS..... Modbus (Specify at order)



ENDA EDT5411A is intended for installation in control panels. Make sure that the device is used only for intended purpose. The electrical connections must be carried out by a qualified staff and must be according to the relevant locally applicable regulations. During an installation, all of the cables that are connected to the device must be free of electrical power. The device must be protected against inadmissible humidity, vibrations, severe soiling and make sure that the operation temperature is not exceeded. The cables should not be close to the power cables or components.

Please see page 4 for Modbus Connection Diagram

Holding screw 0.4-0.5Nm

Equipment is protected throughout by DOUBLE INSULATION.

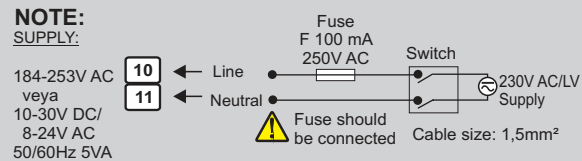
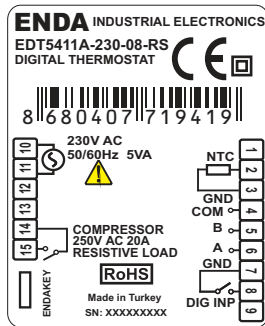
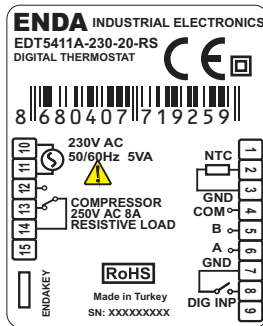

**Note:**  
1) Mains supply cords shall meet the requirements of IEC 60227 or IEC 60245.  
2) In accordance with the safety regulations, the power supply switch shall bring the identification of the relevant instrument and it should be easily accessible by the operator.

ENVIRONMENTAL CONDITIONS	
Ambient / Storage Temperature	0 ... +50°C/-25 ... 70°C (without icing)
Relative Humidity	Max. humidity 80% for temperatures up to 31°C decreasing linearly to 50% relative humidity at 40°C.
Protection Class	According to EN60529; Front panel : IP65, Rear panel : IP20
Height	Max. 2000m
KEEP AWAY device from exposed to corrosive, volatile and flammable gases or liquids and DO NOT USE the device in similar hazardous locations.	
ELECTRICAL CHARACTERISTICS	
Supply Voltage	230V AC +%-10-%20, 50/60Hz;10-30V DC / 8-24V AC SMPS
Power Consumption	Max. 5VA
Connection	2.5mm <sup>2</sup> screw-terminal connections
Scale	-60.0 ... +150.0°C (-76.0 ... +302.0°F)
Sensitivity	0.1°C (Can be selected as 0.1°C or 1°C.)
Accuracy	±1°C
Time Accuracy	±1%
Display	4 Digits, 12.5mm, 7 Segment Red LED
EMC	EN 61326-1: 2013
Safety Requirements	EN 61010-1: 2010 (Pollution degree 2, overvoltage category II)
OUTPUTS	
Relay Output	For EDT5411A-X-R ; Relay : NO+NC 250V AC,8A (resistive load), 1/2HP, 0.37KW 240V AC (inductive load) For EDT5411A-X-P ; Relay : NO 277V AC,20A (resistive load), 1/2HP, 0.37KW 250V AC (inductive load)
Life Expectancy for Relay	For EDT5411A-X-R ; Without load 30.000.000 mechanical; 250V AC, 8A resistive load 100.000 electrical operation. For EDT5411A-X-P ; Without load 10.000.000 switching; 277V AC,20A (for resistive load) 100.000 electrical operation.
CONTROL	
Control Type	Single set-point control
Control Algorithm	On-Off control
Hysteresis	Adjustable between 1 ... 20.0°C.
HOUSING	
Housing Type	Suitable for flush -panel mounting
Dimensions	W54xH94xD68mm
Weight	Approx. 190g (After packing)
Enclosure Material	Self extinguishing plastics.
Avoid any liquid contact when the device is switched on. <b>DO NOT</b> clean the device with solvent (thinner, gasoline, acid etc.) and / or abrasive cleaning agents.	

## DIMENSIONS

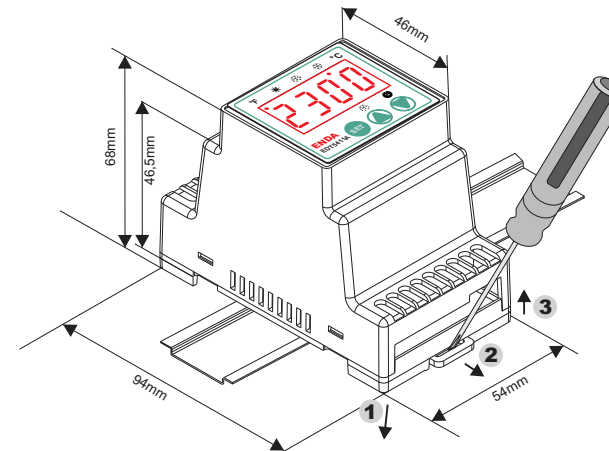

To mounting the device to the panel ; Push the device in direction **1**, the rails provide the key to keeping the rail.

To removing the device from rail ; Push the rail lock in direction **2** with a screwdriver and pull the device in direction **3**.



SISEL MÜHENDİSLİK ELEKTRONİK SAN. VE TİC. A.Ş.  
Serifali Mah. Barbaros Cad. No:18 Y.Dudullu 34775  
ÜMRANIYE/İSTANBUL-TÜRKİYE  
Tel : +90 216 499 46 64 Pbx. Fax : +90 216 365 74 01  
url : www.enda.com.tr



EDT5411-EN-02-220103



- °F FAHRENHEIT LED : This LED lights up if the temperature unit set to "°F" or during parameter value displaying. Also, indicates the parameter if its have been in hidden menu.
- ☀ HEATING LED : Lights up, if the output is activated during heating process.
- ❄ DEFROST LED : Lights up while defrosting process.
- ❄ COMPRESSOR LED : Lights up, if the compressor output is activated. It is flashes while waiting compressor delay.
- SET Used for displaying and configuring the selected parameter value.
- ⬆ Used for increasing the setpoint value and changing parameters. When held down for a few seconds, configured numeric value increases faster.
- ⬇ Used for decreasing the setpoint value and changing parameters. When held down for a few seconds, configured numeric value decreases faster.

## FRONT PANEL COMMANDS

### 1. Viewing and Changing The Set Value



While in "Running Mode", if SET key is pressed set value is displayed for 3 seconds. While in this case, the set value is changed with ⬆/⬇ keys.

### 2. Locking and Unlocking Keys

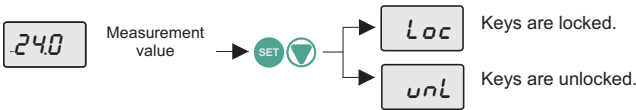

While in "Running Mode", if SET + ⬆ keys are pressed together for 2 seconds, Loc message is displayed and the keys are locked. If the keys are locked SET + ⬆ keys are pressed for 2 seconds again, unL message is displayed and keys are unlocked. While keys are locked and if SET key is pressed, set value can be displayed but can not be changed. While the keys are locked and if any key is pressed (except SET key), Loc message appears.

### 3. Manuel Defrost Process

While in the "Running Mode", if ⬆ key is pressed for 2 seconds, defrost process starts manually. If ddur parameter is 0, manual defrost will be inactive.

### 4. Activating / Inactivating The Control Outputs

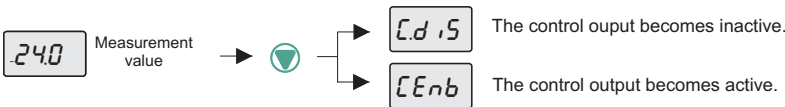

\* When in the "Running Mode", if the control outputs are inactive, oFF message appears periodically.

When in the "Running mode", if ⬆ key is pressed for 2 seconds, C.d.5 message is displayed and control outputs becomes to the inactive position, the device works as the indicator. When the control outputs are disabled; if ⬆ key is pressed for 2 seconds C.Enb is disabled and the device continues to control function.

### 5. Changing Parameter Values

If ⬆ keys are pressed together for 2 seconds L P 1 7 is displayed and "User Menu" is entered, then first parameter's name is displayed in the user menu. While a parameter is selected, by pressing SET key, parameter value can be displayed. This parameter can be changed with ⬆/⬇ keys. If no operation performed for 3 seconds or during this time, SET key is pressed while parameter value displayed, parameter name will be displayed again. While parameter name displayed, if by pressing together ⬆/⬇ keys, "Running Mode" is entered.

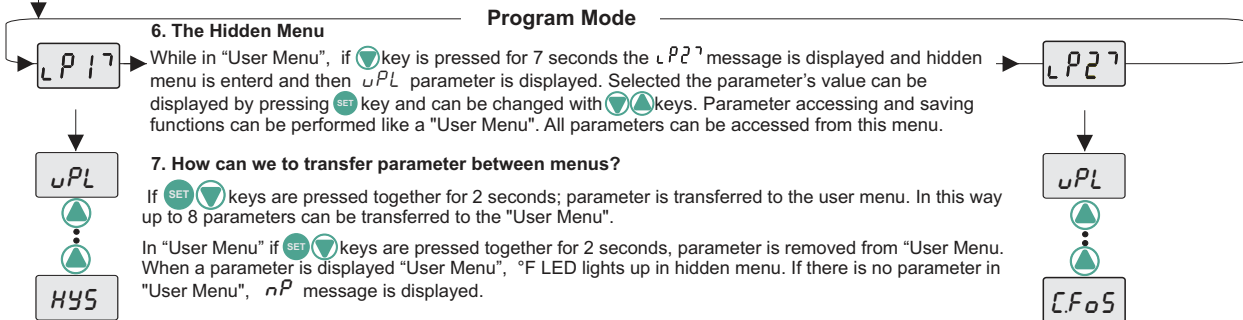

**6. The Hidden Menu**  
While in "User Menu", if ⬆ key is pressed for 7 seconds the L P 2 7 message is displayed and hidden menu is entered and then u P L parameter is displayed. Selected the parameter's value can be displayed by pressing SET key and can be changed with ⬆/⬇ keys. Parameter accessing and saving functions can be performed like a "User Menu". All parameters can be accessed from this menu.

**7. How can we to transfer parameter between menus?**  
If SET + ⬆ keys are pressed together for 2 seconds; parameter is transferred to the user menu. In this way up to 8 parameters can be transferred to the "User Menu".  
In "User Menu" if SET + ⬆ keys are pressed together for 2 seconds, parameter is removed from "User Menu". When a parameter is displayed "User Menu", °F LED lights up in hidden menu. If there is no parameter in "User Menu", n P message is displayed.

## ERROR MESSAGES

- PFA Means, thermostat probe is broken.
- PSC Means, thermostat probe is short circuit.
- Temperature value is higher than the scale.
- Temperature value is lower than the scale.

## ALARM SITUATION

- WW 24.0 AAAA 1. Measurements shown flashes when the alarm condition occurs and if Snd parameter is not 0, audible warning is heard. While warning, by pressing ⬆ key, audible warning can be temporarily disabled.
- WW EA AAA 2. External alarm is active but the outputs are unaffected.
- WW SA AAA 3. External alarm is active and in this state, specifies that the relay outputs are turned off (off state). While warning, by pressing any key, audible warning can be temporarily disabled.

## FACTORY SETTINGS

If ⬆ key is held down while the device is powered up, d.PAR message appears and factory parameters restored.

**PARAMETER TRANSFERING PROCEDURE WITH ENDAKEY**

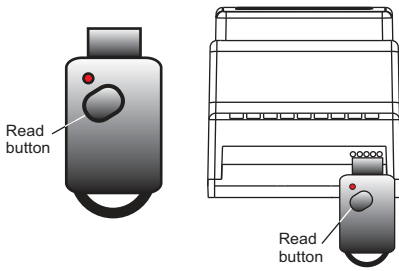

**TRANSFERRING THE PARAMETERS FROM ENDAKEY TO DEVICE**

While in "Running Mode", if key on device or "Read" button on "ENDAKEY" is pressed, "dL" message appears on display and parameters are read and transferred to the device. If the parameter transfer is successful, the "rEF" message appears and the device begins to work with the loaded parameter values. If the parameters are wrong, incorrect or "ENDAKEY" is faulty, "Err" message appears. Parameters will not be changed on device.

**TRANSFERRING THE PARAMETERS FROM DEVICE TO ENDAKEY**

While in "Running Mode", if key is pressed on device, "uL" message appears on display and parameters are read and transferred to the device. If process success, "Suc" message appears. In case of failure, "Err" message appears. Parameters will not be changed on device.

**NOTE 1 :** No power-up required for transferring the parameter by using "ENDAKEY". For long battery life, "ENDAKEY" must be disconnected from device after the transferring process.  
**NOTE 2 :** Please specify at order "ENDAKEY" if required.

CONTROL PARAMETERS		Min.	Max.	UNIT	DEFAULT VALUE
<i>uPL</i>	Upper limit for setpoint	-600	<i>uPL</i>	°C	150
<i>LoL</i>	Lower limit for setpoint	<i>LoL</i>	1500	°C	-60
<i>HYS</i>	Differential cooling (hysteresis)	0.1	200	°C	2
<i>oFF</i>	Offset value for cooling	-200	200	°C	0

CONFIGURATION PARAMETERS					
<i>CLYP</i>	Control type selection ( <i>HE</i> = (*) heating control is selected, <i>Co</i> = Cooling control is selected.) <i>CLYP</i> parameter as <i>HE</i> is selected, the defrost function of the device is disabled.	<i>Co</i>	<i>HE</i>		<i>Co</i>
<i>Unit</i>	Temperature unit	°C	°F		°C
<i>dpnt</i>	Decimal point ( <i>no</i> = decimal point isn't shown 22°C, <i>YES</i> =decimal point is shown 22.3°C.)	<i>no</i>	<i>YES</i>		<i>no</i>
<i>Snd</i>	Type of buzzer sound (6 different voice types can be selected. Alarm during <i>D</i> is chosen, the voice warning is canceled) For Relay-8A is valid.	0	6		0
<i>d.inP</i>	Digital input types. <i>nd</i> : Digital input unused. <i>ER</i> : External alarm. <i>ER</i> message flashes in the display. Output unchanged. <i>SR</i> : Important external alarm. <i>SR</i> message flashes in the display. Relay output is turned off. <i>HL</i> : Control type. <i>CLYP</i> parameter is changed ( If <i>HE</i> = <i>Co</i> , if <i>Co</i> = <i>HE</i> ) <i>dF</i> : Defrost operation is started .	<i>nd</i>	<i>Light</i>		<i>nd</i>
<i>ddi</i>	Digital input delay. The period of the digital inputs to be active.	0:00	99:00		0:00
<i>dPo</i>	Digital input polarity. <i>CL</i> = While a digital input contact is closed, it is activated.	<i>CL</i>	<i>oP</i>		<i>CL</i>

COMPRESSOR PROTECTION PARAMETERS					
<i>CPon</i>	Delay time for the compressor after power is on.	0:00	99:00	min:sec	1:00
<i>CFoS</i>	Delay time required for the compressor to restart following a stop.	0:00	99:00	min:sec	1:00
<i>CPPn</i>	On time for the compressor output in the case of probe failure.	0:00	99:00	min:sec	0:00
<i>CPFF</i>	Off time for the compressor output in the case of probe failure	0:00	99:00	min:sec	1:00

DEFROST CONTROL PARAMETERS					
<i>dSnt</i>	Smart Defrost selection ( <i>no</i> : Defrost counter (between 2 defrost duration) decrease irrespective of <i>d.inL</i> status of the compressor. <i>YES</i> : Defrost counter decreases as long as compressor work).	<i>no</i>	<i>YES</i>		<i>no</i>
<i>ddur</i>	Defrost duration ( If <i>ddur</i> = 0 selected, automatic and manual defrost is disabled )	0:00	99:00	min:sec	1:00
<i>d.inL</i>	Time between 2 consecutive defrosts.	0:00	99:00	hr:min	1:00
<i>ddbP</i>	Display configuration in defrosting process ( <i>rE</i> : Real temperature is displayed during defrost. <i>Lc</i> : During a defrosting process, last measured temperature value is displayed before the defrosting process. This value remains constant until the end of defrosting.	<i>Lc</i>	<i>rE</i>		<i>Lc</i>
<i>ddrE</i>	Delay time for display real temperature after defrost is over.	0:00	99:00	min:sec	1:00
<i>dPon</i>	Defrost process with power. ( <i>no</i> = Defrost process is not started when power-up. <i>YES</i> = Defrost process starts when power-up )	<i>no</i>	<i>YES</i>		<i>no</i>
<i>ddPo</i>	Delay time for defrosting after power-up.	0:00	99:00	min:sec	1:00

ALARM CONTROL PARAMETERS					
<i>RuPL</i>	Limit for upper alarm level. When <i>RtYP</i> is changed, <i>RuPL</i> should be readjusted.	<i>RLoL</i>	1500	°C	150
<i>RLoL</i>	Limit for lower alarm level. When <i>RtYP</i> is changed, <i>RLoL</i> should be readjusted.	-600	<i>RuPL</i>	°C	-60
<i>RHYS</i>	Hysteresis alarm	0.1	200	°C	2
<i>RtYP</i>	Alarm configuration. ( <i>RbS</i> = Independent alarm. Alarm values are <i>RLoL</i> and <i>RuPL</i> ) ( <i>rEF</i> = Relative alarm. Alarm values are <i>SEt</i> - <i>RLoL</i> and <i>SEt</i> + <i>RuPL</i> ) NOTE: Upper and Lower alarm level variables are determined according to the " <i>RtYP</i> " parameter. If <i>RtYP</i> = <i>RbS</i> , <i>RLoL</i> and <i>RuPL</i> . If <i>RtYP</i> = <i>rEF</i> , <i>LoL</i> = <i>SEt</i> - <i>RLoL</i> and <i>RuPL</i> .	<i>RbS</i>	<i>rEF</i>		<i>RbS</i>
<i>RdFL</i>	Time delay to display alarm message after alarm is on.	0:00	99:00	min:sec	0:00
<i>RdPo</i>	Time delay to display alarm message after power is on.	0:00	99:00	hr:min	0:10

MODBUS COMMUNICATION PARAMETERS					
<i>RdrS</i>	Modbus slave device address for device	1	247		1
<i>bRud</i>	Modbus communication speed ( Baud rate, 0 : <i>oFF</i> , 1 : 1200, 2 : 2400, 3 : 4800, 4 : 9600, 5 : 19200 )	<i>oFF</i>	1920	bps	9600

**OUTPUT GRAPHICS**

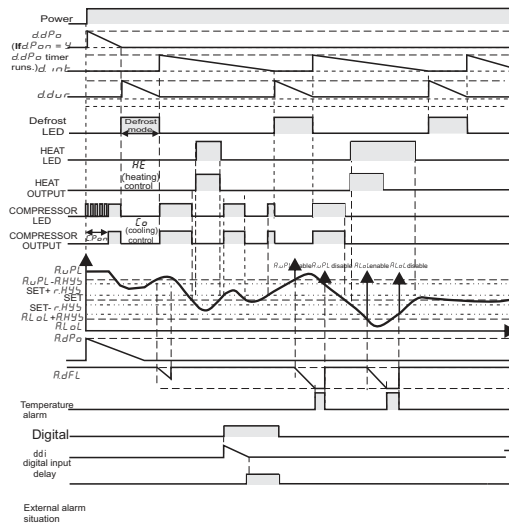

# ENDA EDT5411A DIGITAL THERMOSTAT MODBUS PROTOCOL ADDRESS MAP

## 1.1 HOLDING REGISTERS

Holding Register Addresses		Data Type	Data Content	Parameter Name	Read/Write Permission
Decimal	Hex				
0000d	0x0000	word	Set value	SEt	Read / Write
0001d	0x0001	word	Set point upper limit	uPL	Read / Write
0002d	0x0002	word	Upper level alarm	RuPL	Read / Write
0003d	0x0003	word	Set point lower limit	LoL	Read / Write
0004d	0x0004	word	Lower level alarm	RLoL	Read / Write
0005d	0x0005	word	The offset value for the cooling	oFF	Read / Write
0006d	0x0006	word	Cooling hysteresis	HYS	Read / Write
0007d	0x0007	word	Switch hysteresis for alarm	RHYS	Read / Write
0008d	0x0008	word	Type of buzzer sound	SoNd	Read / Write
0009d	0x0009	word	Digital input types .0=nD;1=ER;2=bR;3=HC;4=dF	d.inP	Read / Write
0010d	0x000A	word	Digital input delay	ddi	Read / Write
0011d	0x000B	word	Delay time for the compressor after power is on.	C.PoN	Read / Write
0012d	0x000C	word	Delay time required for the compressor to restart following a stop.	C.FoS	Read / Write
0013d	0x000D	word	On time for the compressor output in the case of probe failure	C.PPn	Read / Write
0014d	0x000E	word	Off time for the compressor output in the case of probe failure	C.PPF	Read / Write
0015d	0x000F	word	Defrost duration	ddur	Read / Write
0016d	0x0010	word	The time between 2 consecutive defrosts.	d.inE	Read / Write
0017d	0x0011	word	Delay time for defrosting after power is on.	ddPo	Read / Write
0018d	0x0012	word	After the cooling process of cooling start-up delay	ddrE	Read / Write
0019d	0x0013	word	Time delay to display alarm message after alarm is on.	R.dFL	Read / Write
0020d	0x0014	word	Time delay to display alarm message after power is on.	R.dPo	Read / Write

## 1.2 INPUT REGISTERS

Input Register Addresses		Data Type	Data Content	Parameter Name	Read/Write Permission
Decimal	Hex				
0000d	0x0000	word	Measured temperature value (°C / °F)	--	Read

\* Holding and Input Register parameters of type integer, those "signed integer" is defined as the decimal part of and associated with these parameters. (So, "14.0" is a parameter value of "140" will be read in). Relevant parameters for a period of "mm:ss" type ones in seconds, "hh:mm" while those species defined in minutes.

## 1.3 DISCRETE INPUTS

Discrete Input Addresses		Data Type	Data Content	Parameter Name	Read/Write Permission
Decimal	Hex				
0000d	0x0000	Bit	Control output status (0=OFF; 1=ON)	--	Read

## 1.4 COILS

Coil Addresses		Data Type	Data Content	Parameter Name	Read/Write Permission
Decimal	Hex				
00d	0x00	Bit	Control type selection. OFF = Co. ON = HE	C.tYP	Read / Write
01d	0x01	Bit	Temperature unit. OFF = °C, ON = °F	Unit	Read / Write
02d	0x02	Bit	Decimal point. OFF=n0. ON=yE5	dPnt	Read / Write
03d	0x03	Bit	Digital input polarity. OFF = cL. ON = oP	dPo	Read / Write
04d	0x04	Bit	Smart Defrost selection. OFF = n0, ON = yE5	dSnt	Read / Write
05d	0x05	Bit	Display configuration during defrost. OFF = Lc, ON = rE	ddSP	Read / Write
06d	0x06	Bit	Defrost process is started by power-up. OFF = n0, ON = yE5	dPoN	Read / Write
07d	0x07	Bit	Alarm configuration. OFF = RbS, ON = Relative alarm rEF	R.tYP	Read / Write

### \* MODBUS CONNECTION DIAGRAM

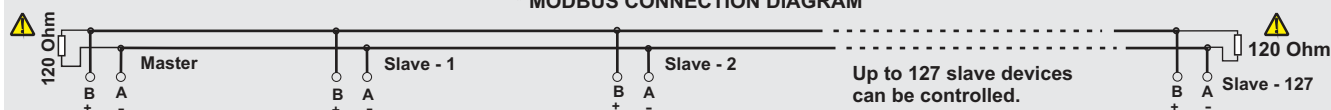

Termination should be accomplished by attaching 120 Ohm resistors to the start and at the end of the communication line.

\* Applies to devices with Modbus function.